



MILLIPORE

Millipore Ireland B.V.

*“Towards Sustainable Production –  
closing water and solvent cycles at  
Millipore”*

Breeda Comyns  
EHS Manager

ADVANCING LIFE SCIENCE TOGETHER™  
Research. Development. Production.

# Company Background

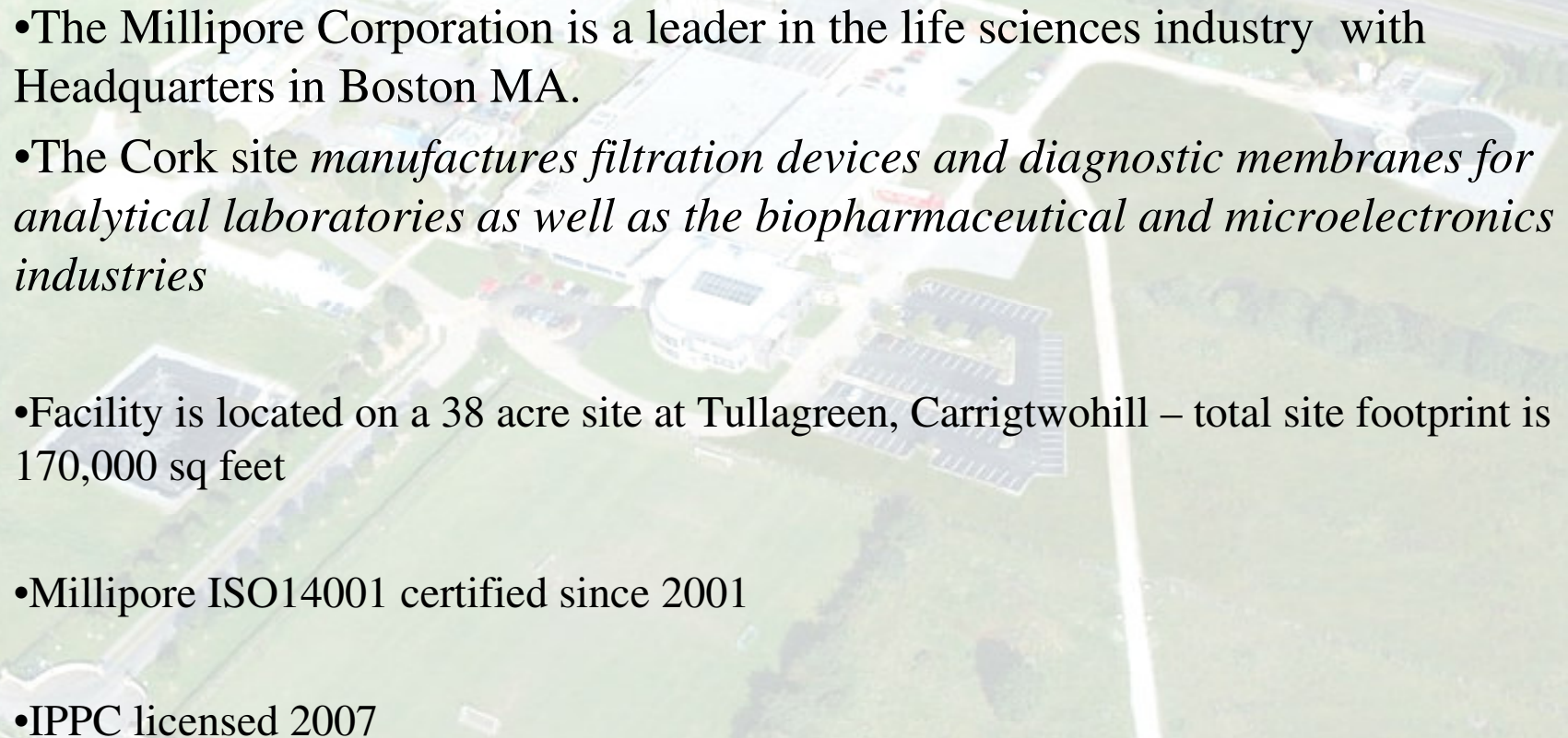
- 
- The Millipore Corporation is a leader in the life sciences industry with Headquarters in Boston MA.
  - The Cork site *manufactures filtration devices and diagnostic membranes for analytical laboratories as well as the biopharmaceutical and microelectronics industries*
  - Facility is located on a 38 acre site at Tullagreen, Carrigtwohill – total site footprint is 170,000 sq feet
  - Millipore ISO14001 certified since 2001
  - IPPC licensed 2007

# CGPP Project- Aims

- Membrane manufacturing process ( Durapore membranes) contaminated wastewater - discharged to the onsite biological WWTP
- This results in the loss of valuable raw materials (ultra pure water and organic solvents)
- The wastewater treatment process is resource intensive (operating costs typically are €0.5M /annum).
- The objective of the s project was to implement technology to recover solvents from specific process streams, for reuse in production. The environmental benefits would include an approximate 80% reduction in COD load to WWTP and consequent savings in energy and natural resources used in the treatment process  
This project would compliment previous work on solvent recovery and solvent reduction projects which were completed.

# Summary of Project

- Inventory of waste streams completed and quantified by CGPP student
- Identified single biggest contributor to loading (VMF4 process)
- Solvent discharged from this process contains 3-4 % Methanol ( too dilute to recover in existing SRU)
- With assistance of Questor centre ( Queens University) a number of other were investigated
- Trial work with membrane technologies ( RO, Pervaporation, zeolites) results which were largely either technically or economically unfeasible
- Direction of the project was then revised and started to focus on avoidance at source

## Condt...

- Reviewed process whereby membrane is wet out with methanol – application of methanol not precise & excess coated on to membrane

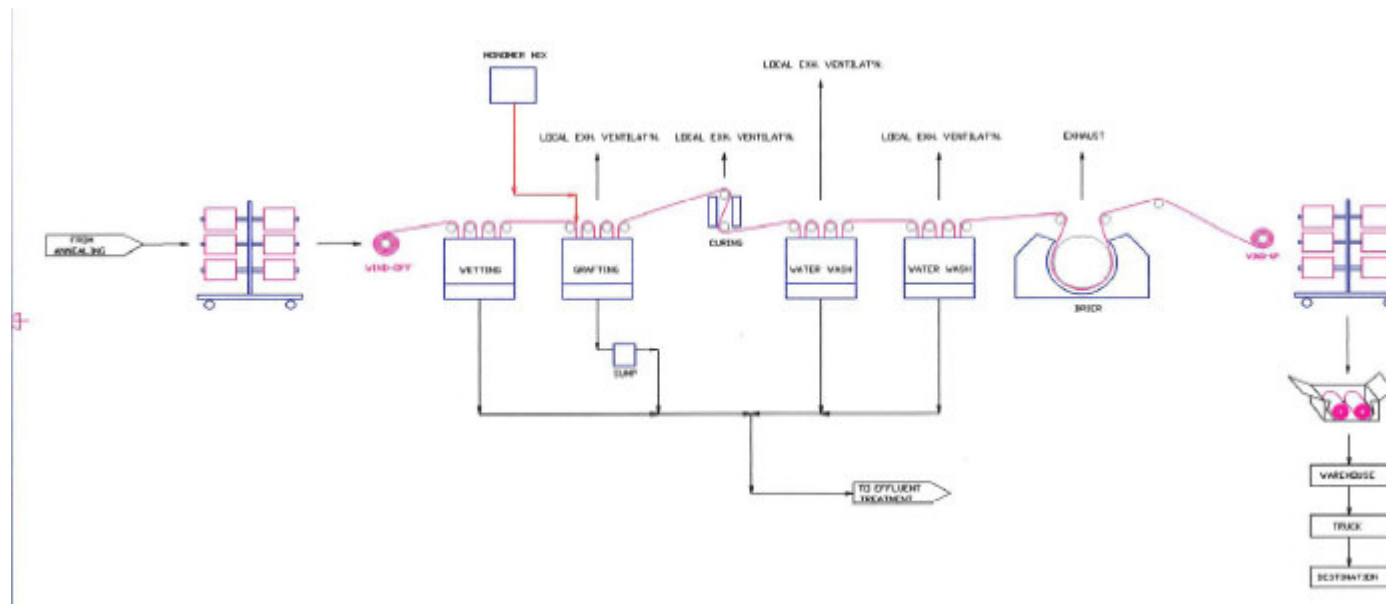

- Number of trials were carried out using a wiper system to remove excess solvent and avoid carry over to the wash tank
- Initial trials were successful with significant reduction
- Overall results showed could reduce COD loading by 73,000Kgs/Annum as well as significant solvent savings 80 tonnes / annum
- Ongoing - challenges as this involves a significant process change and validation
- Lessons learned were used when designing new system/ waste stream was considered and designed in to new SRU system where it will be combined with a very concentrated stream to make recovery economically feasible

# Benefits of CGPP to Millipore

- Greater understanding of Process and where wastes arise
- Student financed under this scheme to carry out analytical work and research not normally possible
- Identified significant area for improvement
- Lessons learned from the project could be transferred to design of new equipment
- Process is a good fit with corporate direction on sustainability & Lean Six Sigma which aim at reducing consumption of natural resources & improving process efficiencies



MILLIPORE

ACCELERATING GROWTH AND INNOVATION

ADVANCING LIFE SCIENCE TOGETHER™  
Research. Development. Production.