

STRIVE

Report Series No.14

Energy Efficiency Improvement of Wastewater Treatment Processes - Using Process Integration Techniques

STRIVE

Environmental Protection
Agency Programme

2007-2013

Environmental Protection Agency

The Environmental Protection Agency (EPA) is a statutory body responsible for protecting the environment in Ireland. We regulate and police activities that might otherwise cause pollution. We ensure there is solid information on environmental trends so that necessary actions are taken. Our priorities are protecting the Irish environment and ensuring that development is sustainable.

The EPA is an independent public body established in July 1993 under the Environmental Protection Agency Act, 1992. Its sponsor in Government is the Department of the Environment, Heritage and Local Government.

OUR RESPONSIBILITIES

LICENSING

We license the following to ensure that their emissions do not endanger human health or harm the environment:

- waste facilities (e.g., landfills, incinerators, waste transfer stations);
- large scale industrial activities (e.g., pharmaceutical manufacturing, cement manufacturing, power plants);
- intensive agriculture;
- the contained use and controlled release of Genetically Modified Organisms (GMOs);
- large petrol storage facilities.

NATIONAL ENVIRONMENTAL ENFORCEMENT

- Conducting over 2,000 audits and inspections of EPA licensed facilities every year.
- Overseeing local authorities' environmental protection responsibilities in the areas of - air, noise, waste, waste-water and water quality.
- Working with local authorities and the Gardaí to stamp out illegal waste activity by co-ordinating a national enforcement network, targeting offenders, conducting investigations and overseeing remediation.
- Prosecuting those who flout environmental law and damage the environment as a result of their actions.

MONITORING, ANALYSING AND REPORTING ON THE ENVIRONMENT

- Monitoring air quality and the quality of rivers, lakes, tidal waters and ground waters; measuring water levels and river flows.
- Independent reporting to inform decision making by national and local government.

REGULATING IRELAND'S GREENHOUSE GAS EMISSIONS

- Quantifying Ireland's emissions of greenhouse gases in the context of our Kyoto commitments.
- Implementing the Emissions Trading Directive, involving over 100 companies who are major generators of carbon dioxide in Ireland.

ENVIRONMENTAL RESEARCH AND DEVELOPMENT

- Co-ordinating research on environmental issues (including air and water quality, climate change, biodiversity, environmental technologies).

STRATEGIC ENVIRONMENTAL ASSESSMENT

- Assessing the impact of plans and programmes on the Irish environment (such as waste management and development plans).

ENVIRONMENTAL PLANNING, EDUCATION AND GUIDANCE

- Providing guidance to the public and to industry on various environmental topics (including licence applications, waste prevention and environmental regulations).
- Generating greater environmental awareness (through environmental television programmes and primary and secondary schools' resource packs).

PROACTIVE WASTE MANAGEMENT

- Promoting waste prevention and minimisation projects through the co-ordination of the National Waste Prevention Programme, including input into the implementation of Producer Responsibility Initiatives.
- Enforcing Regulations such as Waste Electrical and Electronic Equipment (WEEE) and Restriction of Hazardous Substances (RoHS) and substances that deplete the ozone layer.
- Developing a National Hazardous Waste Management Plan to prevent and manage hazardous waste.

MANAGEMENT AND STRUCTURE OF THE EPA

The organisation is managed by a full time Board, consisting of a Director General and four Directors.

The work of the EPA is carried out across four offices:

- Office of Climate, Licensing and Resource Use
- Office of Environmental Enforcement
- Office of Environmental Assessment
- Office of Communications and Corporate Services

The EPA is assisted by an Advisory Committee of twelve members who meet several times a year to discuss issues of concern and offer advice to the Board.

EPA STRIVE Programme 2007–2013

**Energy Efficiency Improvement of Waste-Water
Treatment Processes Using
Process Integration Techniques
(2005-ET-DS-21-M3)**

STRIVE Report

End of Project Report available for download on <http://erc.epa.ie/safer/reports>

Prepared for the Environmental Protection Agency

by

University of Limerick

Authors:

**Toshko Zhelev, Dora Jamniczky-Kaszas, Beata Brzyszc, Marion Trévarain,
Robert Kovacs and Natasha Vaklieva-Bancheva**

ENVIRONMENTAL PROTECTION AGENCY

An Ghníomhaireacht um Chaomhnú Comhshaoil
PO Box 3000, Johnstown Castle, Co. Wexford, Ireland

Telephone: +353 53 916 0600 Fax: +353 53 916 0699

E-mail: info@epa.ie Website: www.epa.ie

ACKNOWLEDGEMENTS

This report is published as part of the Science, Technology, Research and Innovation for the Environment (STRIVE) Programme 2007–2013. The programme is financed by the Irish Government under the National Development Plan 2007–2013. It is administered on behalf of the Department of the Environment, Heritage and Local Government by the Environmental Protection Agency which has the statutory function of co-ordinating and promoting environmental research.

DISCLAIMER

Although every effort has been made to ensure the accuracy of the material contained in this publication, complete accuracy cannot be guaranteed. Neither the Environmental Protection Agency nor the author(s) accept any responsibility whatsoever for loss or damage occasioned or claimed to have been occasioned, in part or in full, as a consequence of any person acting, or refraining from acting, as a result of a matter contained in this publication. All or part of this publication may be reproduced without further permission, provided the source is acknowledged.

The EPA STRIVE Programme addresses the need for research in Ireland to inform policymakers and other stakeholders on a range of questions in relation to environmental protection. These reports are intended as contributions to the necessary debate on the protection of the environment.

EPA STRIVE PROGRAMME 2007–2013

Published by the Environmental Protection Agency, Ireland

ISBN: 978-1-84095-019-9

Price: Free

Online version

Details of Project Partners

Toshko Zhelev

Department of Chemical & Environmental Science
University of Limerick
Castletroy Technological Park
Limerick
Ireland

Tel.: +353 86 8523735

E-mail: toshko.zhelev@ul.ie

Beata Brzyszc

Department of Chemical & Environmental Science
University of Limerick
Castletroy Technological Park
Limerick
Ireland

Robert Kovacs

Department of Technology & Economics and
Department of Chemical & Environmental Engineering
Budapest University of Technology and Economics
Budapest
Hungary

E-mail: Robert.kovacz@mail.bme.hu

Dora Janniczky-Kaszas

Department of Chemical & Environmental Science
University of Limerick
Castletroy Technological Park
Limerick
Ireland

E-mail: kasza2@yahoo.com

Tel.: + 36 20 337 55 34

Marion Trévarain

Department of Chemical Engineering
University of Toulouse, France
8, Allées des Sciences Appliquées
R3 studio 1759
31400 Toulouse
France

Natasha Vaklieva-Bancheva

Process Systems Engineering Laboratory
Institute of Chemical Engineering
Bulgarian Academy of Sciences
Acad. G. Bonchev Str., bl. 103
Sofia 1113
Bulgaria

Tel: +35 9898939611

E-mail: vaklieva@bas.bg

Table of Contents

| | |
|--|------------|
| Acknowledgements | ii |
| Disclaimer | ii |
| Executive Summary | vii |
| 1 Waste-Water Treatment and Energy | 1 |
| 2 Goals of the Research | 2 |
| 3 Analysis | 3 |
| 3.1 Hypothesis for Energy Efficiency Solution | 5 |
| 4 Methodology | 6 |
| 4.1 Mathematical Modelling | 6 |
| 4.2 Heat Integration Using the Process Integration Technique | 6 |
| 4.2.1 Observations (two-reactor configuration dealing with load fluctuation) | 6 |
| 4.2.2 Data extraction | 7 |
| 4.3 Optimisation of the Heat Integration Scheme | 8 |
| 4.3.1 Heat integration model | 9 |
| 4.3.2 Formulation and solution of the optimisation problem | 9 |
| 4.3.3 Optimisation comments | 11 |
| 4.4 Modelling after Heat Integration | 11 |
| 4.5 Heat Integration with Rescheduling | 11 |
| 4.6 Elimination of the Filter Belt Press | 13 |
| 5 Results and Discussion | 14 |
| 5.1 Additional Considerations (General and Specific) | 15 |
| 5.2 Combined Management of Water and Energy | 15 |
| 6 Conclusions | 16 |
| 7 Future Work | 17 |
| 8 References | 18 |
| Abbreviations | 19 |

Executive Summary

This project contributes to the area of energy management of waste-water treatment processes. An important goal is the improvement of the cost-attractiveness of waste-water treatment facilities while maintaining a high level of efficiency. The chosen means of achieving this goal is through application of the energy integration concept. Killarney Waste-Water Treatment Plant (WWTP), and in particular its sludge treatment section, was chosen as a case study for the aerobic treatment investigation. This choice was supported by the fact that the Autothermal Thermophilic Aerobic Digestion (ATAD) type of sludge treatment used in Killarney is quite suitable for average-size settlements, but is energy intensive compared with other treatment concepts. The project succeeded in proving the following hypothesis – that energy efficiency can be improved by applying heat integration principles.

For this case study an efficiency improvement of 11% can be achieved with minor redesign of the plant including one heat exchanger, a storage tank and corresponding re-piping and control system reprogramming. The payback period is 5 years, with a number of additional benefits supplementing increased energy efficiency, including better dewatering of effluent, more controlled foaming in the reactors, easier and quicker transfer of fresh sludge because of improved viscosity, better odour control, and quicker biodegradation because of the suppressed thermal shock. The project reports a number of other scientific

contributions to the formulation of the problem of optimal heat integration under specific conditions (variable temperatures, semi-batch operations, load fluctuations, etc.), plant flexibility improvement, achievement of thermophilic temperature in both reactors, and shortening the aeration and biodegradation time.

The proposed heat integration solution offers a 46% decrease of the temperature shock caused by the cold fresh sludge charge during winter and a 40% decrease of the same shock during summer. This is accompanied by shortening of reactor residence time by 12% (which equates to an approximate reduction of residence time by 5–6 h) and reducing the corresponding electricity required for mixing and aeration. This can be estimated as savings of 11% of electrical energy per tonne of sludge treated, which can result in significant savings to waste-water treatment operators.

The second-stage improvement includes the utilisation of the heat of the gas discharged from reactors and delivered to the Mona-shell absorber.

The research in the chosen area continues because there are indications for possible energy-integration-related improvements which can lead to substantial plant capacity expansion.

The developed concept can be extended to other WWTPs.

1 Waste-Water Treatment and Energy

Water and waste-water utilities in the USA consume 2% of the total amount of electricity produced (Batts *et al.*, 1993). Energy is also the main cost component in the running costs of waste-water treatment plants (WWTPs). Typically, 30% of the operating cost of a waste-water treatment plant is budgeted for energy use, as observed by Tchobanoglous *et al.* (2003). Sludge treatment often represents more than 50% of the total waste-water treatment cost. As the energy bill is a substantial part of the operational cost, it also provides opportunities for cost savings. Rising energy prices and the continual necessity for local authorities to reduce operating costs have increased the interest in saving energy during waste-water treatment

processes without affecting the effluent quality. Efficient energy usage and other energy management measures, such as effective procurement of energy from the supplying utility, are crucial for the improvement of a plant's economic performance. The design and operation of WWTPs, including sludge treatment processes, have a special focus on improved energy efficiency and a reduced cost of treatment. Selected processes must comply with multiple constraints in waste-water and sludge treatment, such as discharge standards for the health and safety of people and environmental protection, reliable operations, and capacity to meet customer demand, all at minimum cost.

2 Goals of the Research

Environmental and legislative constraints regarding sludge disposal, such as its application on agricultural land, stimulate research in this area. Since municipalities are responsible for sludge disposal and finance it from taxpayers' money, cost is the major constraint in providing this service. Therefore, research must provide economically viable solutions. The Autothermal Thermophilic Aerobic Digestion (ATAD) process (see Chapter 2 of the Main Report for further detail) for the treatment of sludge is one practical solution that enables the reuse of sludge in agriculture, though its high energy demand reduces its appeal. One of the main attractions of the ATAD process is its stability (ability to operate under changeable conditions) and low sensitivity (using naturally grown micro-organisms that are operational in a wide range of operating conditions). The inherent high energy consumption of this otherwise very attractive treatment process plays an important role in our process selection and preferred choice. Our hypothesis is that the cost-efficiency of the ATAD process could be enhanced by improving its energy performance. To prove this hypothesis, the main objective of the reported research is to improve the ATAD energy efficiency. The following steps were identified as necessary to achieve the main objective of this project:

- Analyse the ATAD process to estimate the scope for energy efficiency improvement
- Improve energy efficiency of the ATAD system without undermining its current operational performance in terms of vector attraction and pathogen reduction in the sludge produced
- Choose a suitable case study
- Analyse the general energy demand and consumption and generate possible improvements
- Propose feasible and economical solutions for the chosen case study
- Evaluate the suggested design changes
- Present recommendations for enhanced ATAD process operation
- Provide design/redesign guidelines for improved ATAD reactor design that can be employed in the future
- Identify possible further improvements accompanying the search for higher energy efficiency
- Make general conclusions and recommendations.

3 Analysis

Typical operation parameters of the ATAD sludge treatment are shown in Table 3.1. The energy consumption of the ATAD process depends on the number of reactors in use as shown in Table 3.2.

The information given in Table 3.3 outlines the total aeration power supplied in the two-reactor train configuration. This information may help to evaluate

the effect of eventual shortening of hydraulic retention time.

Faster reaction rates lead to faster process treating of the same volume of sludge, and decrease the average retention time. More stable operating conditions and reduced retention time would have a positive impact on the aeration energy usage per sludge volume treated.

Table 3.1. Typical operational conditions of Autothermal Thermophilic Aerobic Digestion (ATAD) based on a variety of operational plants (Stentiford, 2001).

| Parameter | Value |
|--|---|
| Influent total solids (%) | 4–6 |
| Volatile solids (% of dry solids) | 60 |
| Sludge type | Primary, secondary activated sludge or trickling filter, mixture of primary and secondary, manure, domestic or industrial |
| Hydraulic retention time (days) | 4–30 Most common retention time in Killarney is 7 days |
| Air supply ((m ³ /h air)/m ³) | 4 |
| Specific power | 85–105 W/m ³ active reactor volume |
| Volatile solid reduction | 25–56 (Killarney – 36) |
| Number of reactors | Typically two, operating in daily semi-batch, |
| Overall heat transfer coefficient of reactor walls | 0.3–0.4 W/(m ² .°C) |
| Temperature and pH in Reactor 1 | 35–50°C and pH ~7.2 |
| Temperature and pH in Reactor 2 | 50–65°C and pH ~8.0 |

Table 3.2. Breakdown of energy consumption.

| | R1 | R2 | Two reactors operating | Four reactors operating |
|---|----|----|------------------------|-------------------------|
| Spiral aerator (kW) | 11 | 9 | 20 | 40 |
| Central aerator (kW) | 4 | 4 | 8 | 16 |
| Total aeration power (kW) | 15 | 13 | 28 | 56 |
| Foam cutters (kW) | 3 | 3 | 6 | 12 |
| Total power (kW) | 18 | 16 | 34 | 68 |
| Theoretical specific aeration power requirement (W/m ³) | | | 140 | 140 |
| Theoretical specific power requirement (W/m ³) | | | 170 | 170 |
| Throughput energy (kWh/m ³) | | | 39 | 50 |
| Theoretical energy at maximum load (kWh/m ³) | | | 32.5 | 24 |

Table 3.3. Aeration power requirement.

| | Two-reactor configuration | |
|---|---------------------------|----------------|
| | Average | Maximum design |
| Raw sludge volatile solids (%) | 4.6 | |
| Effluent volatile solids (%) | 2.4 | |
| Average volatile solids reduction (g/l or kg/m ³) | 22 | |
| Load (m ³) | 20 | 24 |
| Daily volatile solids digested (kg) | 440 | 528 |
| Oxygen requirement (kg O ₂ /day) | 625 | 750 |
| Aeration requirement (kg O ₂ /h) | 41 | 49 |
| Total aeration power requirements (kWh) | 22 | 27 |

A shorter retention time corresponds to decreased energy usage per cubic metre of sludge feed. Alternatively, the same amount of aeration energy would be used for an increased amount of sludge treated. The electrical energy saving per cubic metre of sludge (e.g. savings in electricity used for aeration minus the electricity used for extra pumping due to the heat exchangers) could be used to explicitly demonstrate the benefit of any process improvement.

Although ATAD is a thermophilic process, the first reactor, in the usual series of reactors, might not

operate in this temperature range as illustrated in Fig. 3.1.

As reported earlier (Deeny *et al.*, 1991), in a two-stage batch ATAD system, the temperature in the first-stage reactor tends to fall by an average of 5–10°C, with a recovery rate of approximately 1°C/h after feed is added, with a 33% reactor volume displacement. The temperature drop in the second reactor ranges from 4 to 6°C, with a higher recovery rate. The temperature drop after feeding, when sludge is added with a lower temperature to the partially digested sludge, is called the thermal shock. The first-stage digester does not

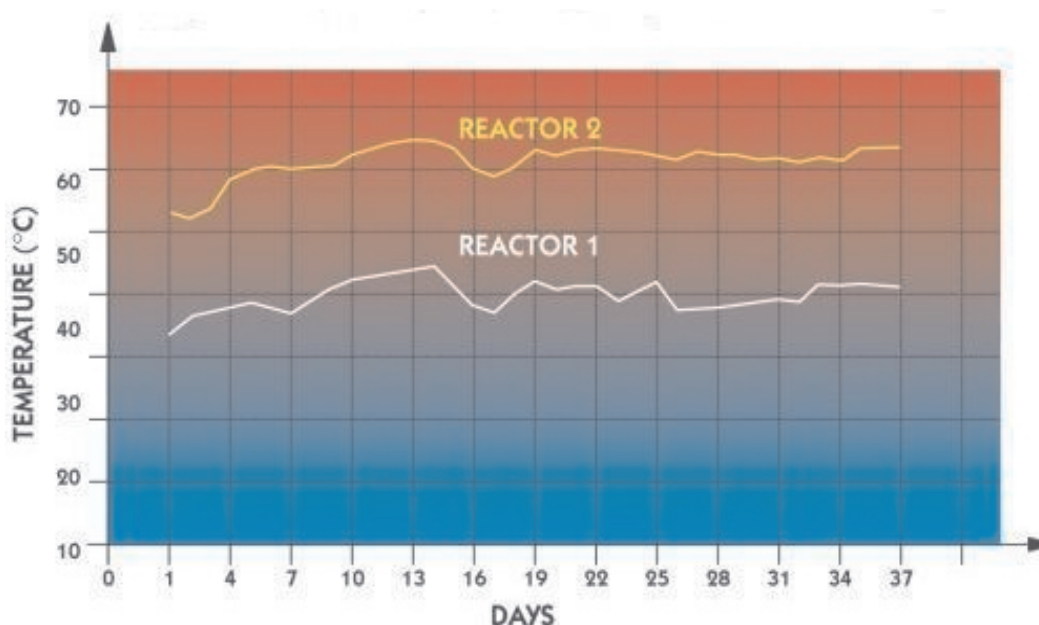

Figure 3.1. Typical temperatures in the Autothermal Thermophilic Aerobic Digestion (ATAD) reactors with two reactors in series (Fuchs, GmbH <http://www.fuchs-germany.com>).

maintain temperatures above 50°C because it takes considerable time to recover from the thermal shock. Usually, in the first reactor (or reactors), the sludge reaches thermophilic conditions at the end of each cycle and, in this way, the second (or last) reactor in the series can constantly operate in the thermophilic temperature range.

3.1 Hypothesis for Energy Efficiency Solution

Temperature strongly influences the reaction rates of the process. Increasing the temperature to a certain extent speeds up the reaction process and shortens the reaction time. Therefore, if the thermal shock was eliminated or changed by reducing its duration or extent, the thermophilic temperature range could be reached quicker in the first reactor and the process would operate for longer in the thermophilic temperature range. Eliminating or reducing the operation in the mesophilic temperature range and increasing it in the thermophilic temperature range would lead to more stable and favourable operational conditions and improved reaction rates.

Improved operating conditions, such as reduced foaming when applying sludge feed preheating, were published by Kelly and Warren (1997). Improved reaction rates arise because biochemical reaction rates generally increase exponentially with temperature. However, excessively high process temperatures can thermally inactivate the microbial population – in this case, temperature becomes rate limiting. As temperature increases after a certain point, digestion decreases in the tanks so the process is closed as autothermal in this sense; however, in practice it might need external intervention such as cooling to prevent the death of thermophilic bacteria (Kelly and Warren, 1997). There is a danger of resolubilisation of organics at high temperature; therefore, a US EPA report suggests that the temperature in the reactors should not exceed 65°C (US EPA, 2003).

Faster reaction rates lead to a faster process which would treat the same volume of sludge in less time, and decrease the average retention time. The more stable operational conditions and the reduced

retention time would have a positive impact on the aeration energy usage per sludge volume treated.

Shorter retention times would mean that the same volume of sludge spends less time in the reactors which would decrease the energy usage per cubic metre of sludge feed. Alternatively, the same amount of aeration energy would be used for an increased amount of sludge treated. To keep this level of temperature would maximise the performance but, as was noted earlier, the cold sludge feed causes temperature drop leading to temperature shock (because sometimes the micro-organisms stop their biodegradation activities and after the recovery period start to work again). The recovery of the optimal temperature level takes several hours and during this time the process conditions are far from optimal as the analysis above shows. As mentioned previously, maintaining more stable operational conditions will lead to reduced reactor retention time and will have a positive impact on the aeration energy usage per sludge volume treated (defined as treatment efficiency). The above analysis was used to formulate the following hypothesis – that modifications made to the ATAD process to increase the operational temperature can enhance its energy efficiency.

There are several possible solutions to eliminate the thermal shock:

- By elevating operational temperature, so the temperature would always stay in the thermophilic temperature range
- By changing the feeding process (feeding pattern and frequency). Instead of feeding once daily, the same volume could be divided into smaller volumes and these reduced portions could be introduced twice or three times a day to the reactors. The reduced sludge transfer volume would reduce the thermal shock experienced after feeding and would speed up the recovery time to reach the optimal operating temperature
- By changing the temperature of sludge being fed to the system
- By a combination of the above-listed solutions.

4 Methodology

4.1 Mathematical Modelling

Modelling ATAD can be divided into two sub-models that interact with each other: one is the mass balance, and the other is the energy or heat balance. As temperature is one of the most relevant aspects from a performance perspective, a heat balance can facilitate a realistic general ATAD model. The heat balance of the ATAD process makes possible the determination of the temperature in the reactors.

The model used in this investigation was based on the well-known Monod kinetics calibrated by Gomez *et al.* (2007), further extended by the International Water Association into a model version known as the Activated Sludge Model 1 (ASM1), and later validated by Kovacs *et al.* (2007), who extended it to account for the heat generated through biological activity for the thermophilic range of temperatures in ATAD reactors. The details of the ATAD reactor model can be found in Chapter 4 of the Main Report. The application of the model for simulation of the ATAD facility at Killarney demonstrated a very good match with available statistical data over quite a long period of time.

4.2 Heat Integration Using the Process Integration Technique

An important innovative aspect of the study was the formulation and solution of the problem of energy efficiency improvement under typical conditions for tourist locations that place severe seasonal load fluctuations on waste-water treatment.

The calibrated and validated model, as presented in the Main Report, made feasible the examination of different options such as heat recovery and feeding patterns (frequency, configuration, batch volumes).

4.2.1 Observations (two-reactor configuration dealing with load fluctuation)

The green lines in Fig. 4.1 represent low load operating temperatures, while the blue lines show temperature profiles at high load. As one can see, the temperature in the reactors decreases as the load increases (blue lines). The first reactor in this case will operate in the mesophilic temperature range, and the second is unlikely to operate at temperatures above 57°C at all times. The conclusion from this observation is that without any operational or design modification there is a risk of temperature drop which would undermine the

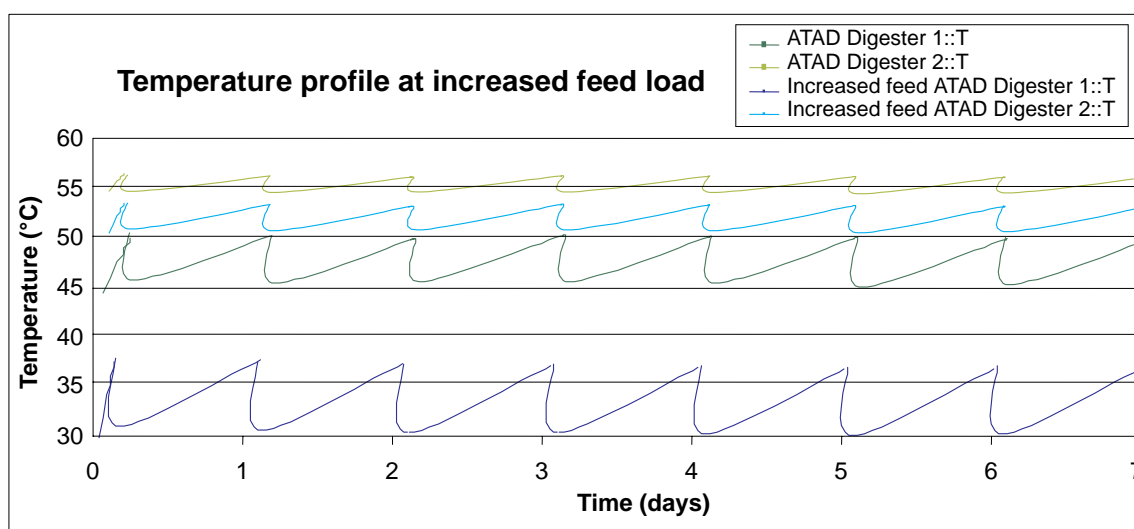

Figure 4.1. Temperature change at increased reactor load.

pathogen elimination and jeopardise compliance with legislation.

4.2.2 Data extraction

Data extraction involves collecting data for the process and the utility system and formulating process streams requiring heating and cooling.

When the streams representing the processes under investigation have been identified, the next stage is to represent the entire process on a temperature-enthalpy diagram by so-called composite curves. These curves show the cumulative heat sources and heat sinks in the process.

The composite curves of streams from Table 4.1 are plotted in Fig. 4.2. It shows the amount of available

heat recovery without the usage of any external utility. This is a special case of heat integration known as the ‘threshold problem’. It occurs when one of the two utilities (external cooling or heating) disappears. Here both utilities are missing. We would specify this case as a ‘dual threshold process’. This is not a coincidence, but a requirement of our design. We would like to have maximum energy utilisation, no waste of energy (by external utility) or even better – no additional heating utility (which can raise the operating costs of the plant) already considered too energy intensive. The sludge supplied from pre-storage to Reactor 1 would ideally be heated to 60°C because this is the level of the operating temperature in the reactor. The analysis will show if this is possible, i.e. if sufficient energy for this is available. Therefore this target temperature is a soft

Table 4.1. Winter stream data.

| Stream name | T _{in} (°C) | T _{out} (°C) | Cp (kJ/kg.°C) | Flow rate (m ³ /day) | Flow rate (kg/day) | Flow rate (kg/s) | ΔH (kW) |
|-------------------------------|----------------------|-----------------------|---------------|---------------------------------|--------------------|------------------|---------|
| Sludge to Reactor 1 | 10 | 55 | 4.00 | 20.0 | 20,500.0 | 11.39 | 2,050.2 |
| Sludge to Reactor 2 | 54 | 64 | 4.00 | 20.0 | 20,500.0 | 11.39 | 455.6 |
| Sludge to storage | 62 | 20 | 4.00 | 20.0 | 20,500.0 | 11.39 | 1,913.5 |
| Air to ATAD (1A & 2A) | 9 | 55 | 1.012 | 6,480.0 | 7,938.0 | 0.09 | 4.19 |
| Air to ATAD (1B & 2B) | 9 | 61 | 1.012 | 6,480.0 | 7,938.0 | 0.09 | 4.74 |
| Total gas to ammonia scrubber | 60 | 10 | 1.012 | 86,400.0 | 91,540.8 | 1.082 | 54.75 |

ATAD, Autothermal Thermophilic Aerobic Digestion. Cp, specific heat capacity.

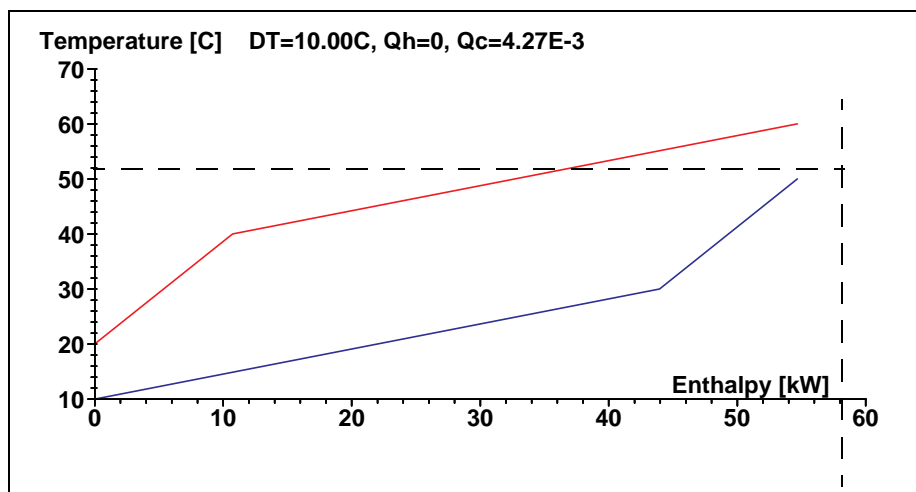

Figure 4.2. Composite curves for selected streams. DT, minimum temperature approach (economically justified); Qh, minimum heating requirements (using external heating utility); Qc, minimum external cooling requirements (using external cooling utility).

datum, which means that the sludge should be heated as much as possible from 12°C to a maximum of 60°C. To achieve this we solve a simple optimisation problem – to fix the ‘floatable’ or ‘soft’ target temperature of the fresh sludge at the highest possible level, before any further heating begins to require an additional energy input. The result is shown in Fig. 4.2. Here the highest reachable temperature of the raw sludge is 50°C.

Up to now the heat integration study was based on the conceptual design approach (Pinch analysis). The competing approach or the adding value approach to the conceptual energy integration problem is the mathematical approach. The benefits that this approach can give to the resolution of the problem in question – the energy efficiency improvement of sludge treatment in one of Ireland’s WWTPs – are presented below.

4.3 Optimisation of the Heat Integration Scheme

The sludge preheating scheme presented in Fig. 4.3 is generated while accounting for the semi-batch mode of operation of the sludge treatment. The heat of the effluent sludge is available in the time period which

precedes (by 1 h) the need for heat when the fresh cold sludge is supplied to Reactor 1. The logical solution to the intent to recover the product heat for preheating of influent sludge is to use storage of heat until the time it can be applied. The proposed scheme comprises one heat storage tank and two counter-current heat exchangers named HE-c and HE-h (Fig. 4.3). During the heating period, HE-c is used for preheating the fresh cold sludge drawn from the feed tank, while in the cooling period the product leaving bioreactor 2-A(B) is cooled in HE-h. A commonly used intermediate fluid is proposed to play the role of a ‘heating’ or ‘cooling’ agent. It will recirculate between the heat tank and the corresponding heat exchangers in predetermined time periods. The heat exchange is non-stationary. Neglecting heat losses, a detailed mathematical model of a heat-exchange scheme similar to the proposed one is presented by Ivanov *et al.* (1993). It provides an opportunity to determine the target temperatures of preheated sludge and the cooled product as functions of the main parameters of the heat integration scheme.

A developed heat integration model is used for optimisation purposes. The goal is to find the cheapest heat integration design scheme that maximises the

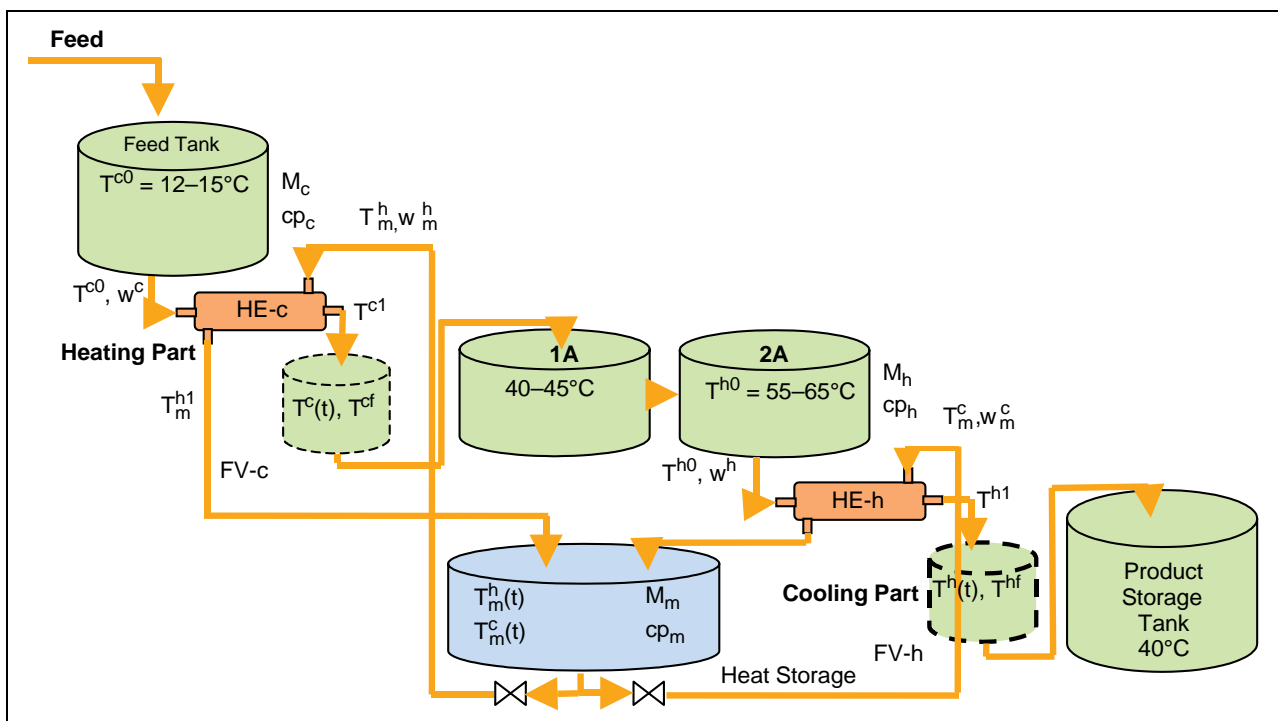

Figure 4.3. Proposed heat integration scheme.

utilisation of available process heat (reaching the highest temperature of fresh sludge, i.e. minimising the temperature shock).

4.3.1 Heat integration model

During the heating period cold sludge enters HE-c, with a known and constant temperature T^{c0} , which becomes T^{c1} in the end of the period τ_c :

$$T^{c1} = T^{c0} + (T_m^h - T^{c0})R^c\Phi e^c \quad (1)$$

Meanwhile, the supply (T_m^h) and target (T_m^{h1}) temperatures of the intermediate fluid are:

$$T_m^h = T^{c0} + (T_m^{h0} - T^{c0})\exp(-G_m^h\Phi e^c\tau_c) \quad (2)$$

$$T_m^{h1} = T_m^h - (T_m^h - T^{c0})\Phi e^c \quad (3)$$

where:

$$R^c = \frac{w_m^h cp_m}{w_c cp_c}; \quad w_c = \frac{M_c}{\tau_c} \text{ [kg/sek]}; \quad w_m^h = \frac{M_m}{\tau_c} \text{ [kg/sek]}$$

$$\Phi e^c = \frac{1 - \exp(-y_c U_c A_c)}{1 - R^c \exp(-y_c U_c A_c)}; \quad y_c = \frac{1}{w_m^h cp_m} - \frac{1}{w_c cp_c} \quad \text{and}$$

$$G_m^h = \frac{w_m^h}{M_m} \text{ [sek}^{-1}\text{]}$$

A_c and A_h are heat exchange areas of HE-c and HE-h (m^2) and M_m is the mass of the intermediate fluid (kg); cp_c and cp_m are heat capacities of the fresh sludge and the intermediate fluid.

Likewise, the temperature of the hot product drops from T^{h0} to T^{h1} at the end of cooling period τ_h , while the supply T_m^c and target T_m^{c1} of the intermediate fluid are:

$$T^{h1} = T^{h0} - (T^{h0} - T_m^c)\Phi e^h \quad (4)$$

$$T_m^c = T^{h0} + (T_m^{c0} - T^{h0})\exp(-R^h\Phi e^h G_m^c\tau_h) \quad (5)$$

$$T_m^{c1} = T_m^c + (T^{h0} - T_m^c)R^h\Phi e^h \quad (6)$$

where:

$$R^h = \frac{w_h cp_h}{w_m^c cp_m}; \quad w_h = \frac{M_h}{\tau_h} \text{ [kg/sek]}; \quad w_m^c = \frac{M_m}{\tau_h} \text{ [kg/sek]};$$

$$\Phi e^h = \frac{1 - \exp(-y_h U_h A_h)}{1 - R^h \exp(-y_h U_h A_h)}; \quad y_h = \frac{1}{w_h cp_h} - \frac{1}{w_m^c cp_m}; \quad \text{and}$$

$$G_m^c = \frac{w_m^c}{M_m} \text{ [sek}^{-1}\text{]}$$

where cp_h is the heat capacity of the product.

The starting 'hot' and 'cold' temperatures of the intermediate fluid in the heat tank are denoted as T_m^{h0} and T_m^{c0} . They can be determined according to:

$$T_m^{h0} = \frac{b_{22} + b_{12}b_{21}}{1 - b_{11}b_{21}} \quad \text{and} \quad T_m^{c0} = \frac{b_{12} - b_{11}b_{22}}{1 - b_{11}b_{21}} \quad (7)$$

where:

$$b_{11} = \exp(-G_m^h\Phi e^c\tau_c); \quad b_{12} = [1 - \exp(-G_m^h\Phi e^c\tau_c)]T^{c0}$$

$$b_{21} = \exp(-R^h\Phi e^h G_m^c\tau_h); \quad b_{22} = [1 - \exp(-R^h\Phi e^h G_m^c\tau_h)]T^{h0}$$

4.3.2 Formulation and solution of the optimisation problem

The temperature drop in 1-A(B) caused by the thermal shock differs from season to season. Using averaged data listed in Table 4.2, this temperature is determined to be in the range of 42°C to 51.9°C for winter and summer periods.

The energy efficiency of the proposed integration scheme could be assessed by the temperature in 1-A(B) established after mixing of biomass with the preheated fresh sludge in HE-c. The target temperature T^{c1} of the sludge depends on the parameters of the integration scheme (τ_c , A_c , τ_h , A_h and M_m). The formulation of an optimisation problem aiming to maximise the temperature in bioreactor 1-

Table 4.2. Average values of stream parameters for winter and summer periods.

| | M_c (kg) | Cp_c (J/kg.°C) | T^{c0} (°C) | M_h (kg) | Cp_h (J/kg.°C) | T^{h0} (°C) | $M_{1-A(B)}$ (kg) | $T^{1-A(B)}$ (°C) |
|--------|---------------|---------------------|------------------|---------------|---------------------|------------------|----------------------|----------------------|
| Winter | 20,500 | 4,000 | 10 | 20,500 | 4,000 | 60 | 82,000 | 50 |
| Summer | 15,375 | 4,000 | 17.5 | 15,375 | 4,000 | 60.5 | 87,125 | 58 |

A(B) and its solution at different design conditions will provide a clear working frame for further cost optimal plant retrofitting.

4.3.2.1 Problem description

Data. The formalisation of the optimisation problem requires the following data:

M_c and M_h – masses of raw sludge and product (kg)

T^{c0} and T^{h0} – sludge and product inlet temperatures (°C)

cp_c and cp_h – heat capacities of sludge and product (J/kg.°C)

U_c and U_h – overall heat transfer coefficients of HE-c and HE-h (W/m².°C).

Taking into account that the range of temperatures determined by the cold sludge and hot product is from 10° to 60.5°C, water is chosen as the intermediate fluid (cp_m – 4,190 J/kg.°C). Additionally, the admissible individual minimal temperature difference ΔT_{min} has to be set for each of the two ends of the heat exchangers.

Control variables. Parameters τ_c , A_c , τ_h , A_h and M_m of the integration scheme are introduced as continuous control variables. They are limited in the following ranges:

$$\tau_c^{\min} \leq \tau_c \leq \tau_c^{\max} \quad \text{and} \quad \tau_h^{\min} \leq \tau_h \leq \tau_h^{\max} \quad (8)$$

$$A_c^{\min} \leq A_c \leq A_c^{\max} \quad \text{and} \quad A_h^{\min} \leq A_h \leq A_h^{\max} \quad (9)$$

$$M_m^{\min} \leq M_m \leq M_m^{\max} \quad (10)$$

Mathematical model. The mathematical model includes [Eqns 1–7](#).

Constraints. They ensure feasible heat exchange in HE-c and HE-h:

$$\Delta T_c \geq \Delta T_{min} \quad \text{and} \quad \Delta T_h \geq \Delta T_{min} \quad (11)$$

where ΔT_c and ΔT_h are minimal temperature differences at the corresponding ends of the heat exchangers determined in the following way:

$$\Delta T_c = \min\{(T_m^{h1} - T^{c0}), (T_m^h - T^{c1})\} \quad (12)$$

$$\Delta T_h = \min\{(T^{h0} - T_m^{c1}), (T^{h1} - T_m^c)\} \quad (13)$$

Optimisation criterion. The temperature, TEM , reached after mixing the biomass and the preheated fresh sludge in 1-A(B) is calculated as follows:

$$TEM = \frac{M_c \cdot T^{c1} + M_{1-A(B)} \cdot T^{1-A(B)}}{M_c + M_{1-A(B)}} \quad (14)$$

where $M_{1-A(B)}$ is the mass of the reactor's sludge and $T^{1-A(B)}$ is its temperature.

This temperature is subject to maximisation:

$$\text{MAX}_{\tau_c, \tau_h, A_c, A_h, M_m} (TEM) \quad (15)$$

The formulated optimisation problem can be classified as a typical non-linear programming (NLP) problem.

4.3.2.2 Calculation results

Some heat integration data required for winter and summer operation periods are given in [Table 4.2](#). Assuming mild steel as the building material for the heat exchangers with a wall thickness of 0.004 m and neglecting the thermal resistance of the foulings, the heat transfer coefficients are estimated as $U_c = 657$ (W/m².°C) and $U_h = 657$ (W/m².°C).

Additional data provided by the plant are used to determine the boundaries of the time variables τ_c and τ_h for both periods:

$$\text{Winter:} \quad 60 \leq \tau_c \leq 2,640 \text{ s}; \quad 60 \leq \tau_h \leq 1,320 \text{ s}$$

$$\text{Summer:} \quad 60 \leq \tau_c \leq 1,800 \text{ s}; \quad 60 \leq \tau_h \leq 900 \text{ s}$$

We have assumed the range of heat exchange areas A_c and A_h to be in the range between 0 and 500 m². Bearing in mind that the mass of intermediate fluid (water) plays an important role in the integration process, three values of 30,000, 40,000 and 50,000 kg as the upper limit M_m^{\max} have been considered, while for the bottom limit M_m^{\min} a value of 239 kg was taken to avoid singularity. In addition, the problem is studied at three possible values for ΔT_{min} equal to 5, 7 and 10°C.

The problem is solved at all nine possible combinations between values of M_m^{max} and ΔT_{min} . Results obtained show that the thermal shock in 1-A(B) varies between 45.26°C (best case) and 44.16°C (worst case) for the winter. These temperatures in 1-A(B) correspond to $M_m^{max} = 50,000$ and $\Delta T_{min} = 5^\circ\text{C}$ for the best case, and $M_m^{max} = 30,000$ and $\Delta T_{min} = 10^\circ\text{C}$ for the worst one. They are compensating, correspondingly, for 3.26°C and 2.16°C of the temperature drop caused by the thermal shock without integration. The corresponding exit temperatures of the preheated sludge T^{c1} at the exit of HE-c are 26.28 and 20.81°C. For the summer, the corresponding temperature in 1-A(B) varies between 54.05°C ($M_m^{max} = 50,000$; $\Delta T_{min} = 5^\circ\text{C}$ and $T^{c1} = 31.66^\circ\text{C}$) and 53.27°C ($M_m^{max} = 30,000$; $\Delta T_{min} = 10^\circ\text{C}$ and $T^{c1} = 26.47^\circ\text{C}$), which exceeds the recorded temperature of 51.9°C by 2.12°C and 1.35°C, respectively. The values of the control variables τ_c , A_c , τ_h and A_h are kept within the predefined ranges. All other results are within the constrained ranges for both periods.

Our records show that the heat required by reactor 1-A(B) to avoid the thermal shock in winter is approximately 15.58 GJ per batch. The main part of it comes from the biological activities. The consumption of 1 kg of oxygen releases 14,688 kJ in the form of heat. The considered integration scheme decreases the required heat within a range between 1.335 and 0.886 GJ as set by best and worst cases. The latter affects the oxygen consumption, reducing it to between 91 and 60.3 kg, respectively. Moreover, a temperature shock resulting in a winter temperature drop of 8–10°C is compensated for about 12–14 h. The proposed heat integration solution offers a 46% decrease in the temperature shock during winter and a 40% decrease in the same during summer accompanied by shortening of reactor residence time and reducing the electricity required for mixing.

4.3.3 Optimisation comments

In conclusion, the results presented above define the upper and lower boundaries of the energy efficiency of the proposed integration scheme to serve as cost-optimal retrofitting of the plant. Practically, the process heat recovery and the partial suppression of the thermal shock open a promising way for general efficiency improvement of the sludge treatment in

question. We accept this as the first attempt to address waste-water energy efficiency with the help of a process systems engineering approach. This work opens the prospect for further system improvement. The way ahead is in the combined targeting of energy efficiency improvement with system capacity extension.

4.4 Modelling after Heat Integration

The reactor model introduced in Chapter 5 and validated in Section 8.2 of the Main Report was used to predict (simulate) the thermal behaviour of the reactors after the feed temperature increase through heat integration. As can be seen from Fig. 4.4, the feed preheating can lead both reactors into the thermophilic temperature zone. This shows potential for elimination of one reactor and the important conclusion that the implementation of the process integration concept can lead not only to energy efficiency benefits, but also to side effects that can be much more substantial, in this case an improvement in plant capacity. This option should be carefully evaluated in the future, but it shows a scope for doubling of plant capacity, which would be of great benefit to the plant in question.

4.5 Heat Integration with Rescheduling

Building the mathematical model of the bioreactor was accompanied by a software code developed by Kovacs *et al.* (2007), used for simple process simulation. During his visit to our university he modified this process simulator for the needs of this case study. The program code is called 'Killarney'. It offers an easy interface, which allows easy simulation of different process configurations (structures). Figure 4.5 presents the simulation structure of one promising process structure as a possible alternative to the one optimised in Section 4.3.2. For comparison, Fig. 4.6 demonstrates schematically the current flow structure of the Killarney sludge treatment plant.

The simulation structure from Fig. 4.5 offers an important impact on several operational issues. First, the introduction of an additional storage tank between Reactor 1 and Reactor 2 allows for rescheduling. This means that the corresponding volume of the digested sludge in Reactor 1 (at present 15 m³) can be transferred to storage before the matching volume of

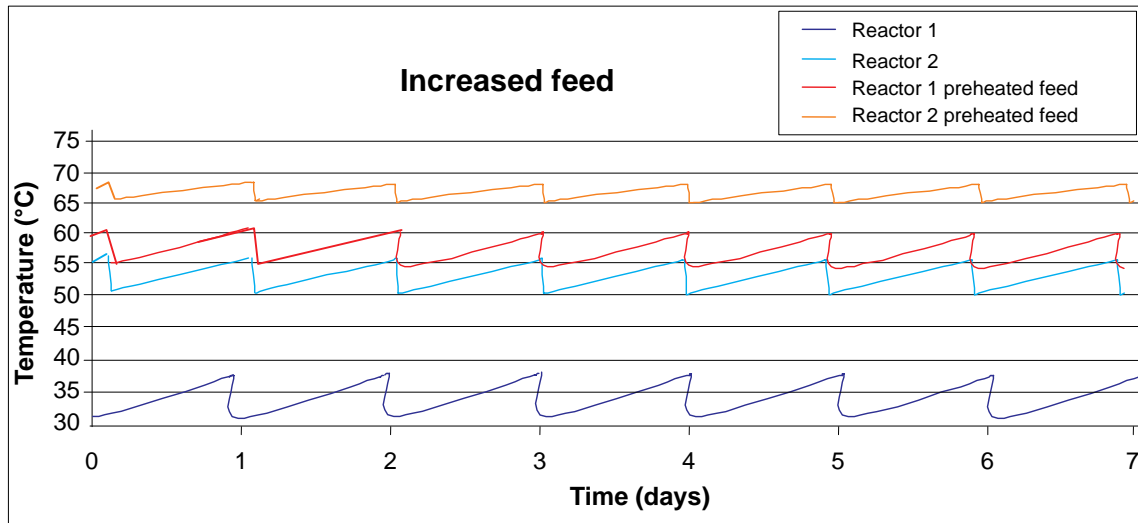

Figure 4.4. Simulation of reactor thermal reaction on feed preheating option.

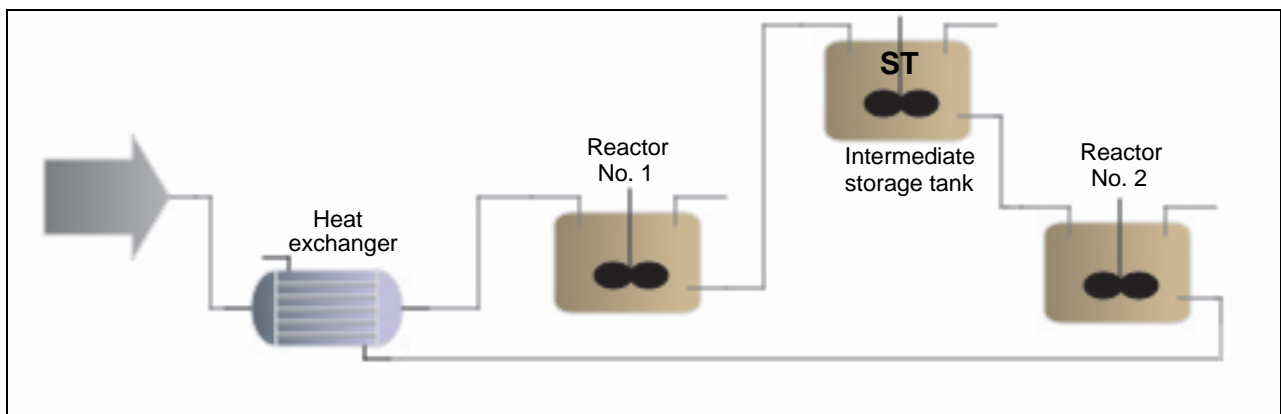

Figure 4.5. Schematic presentation of a modified and rescheduled process scheme.

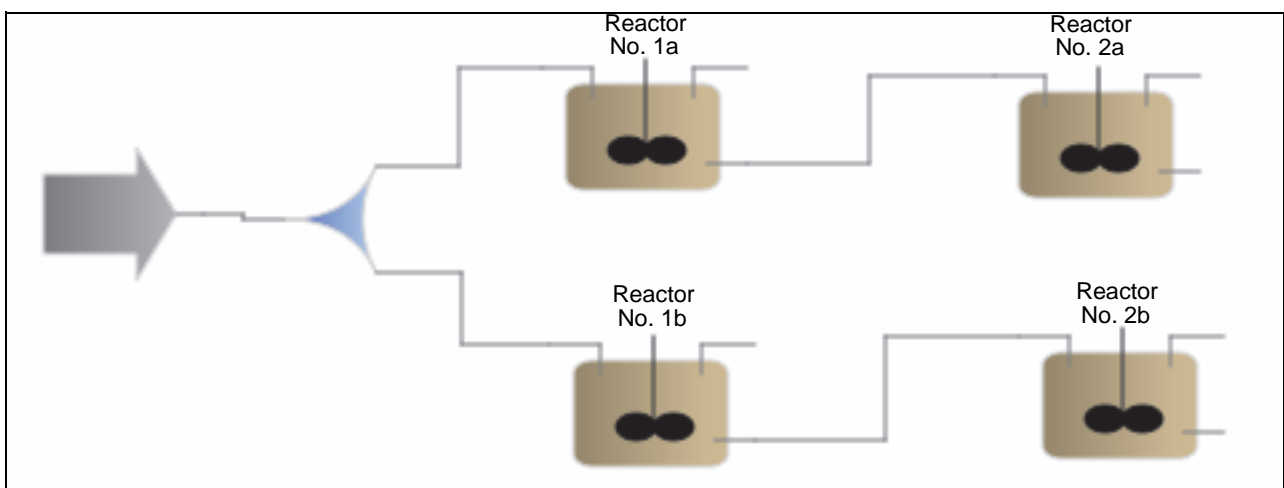

Figure 4.6. Schematic presentation of the current situation in Killarney sludge treatment unit.

sludge is discharged from Reactor 2 (30 min earlier). This will allow matching the time of discharge from Reactor 2 with the time of charge of Reactor 1, which in turn will allow continuous heat exchange in the presented heat exchanger. Thus the batch mode of operation will be changed to the more efficient continuous mode of operation. Second, the proposed scheme modification will save extra heat exchangers (for intermediate fluid heating/cooling) and corresponding pump and electrical energy.

4.6 Elimination of the Filter Belt Press

A major role of the pre-thickener is to provide an adequate level of biodegradable organics for further digestion (eliminating a substantial amount of water). This, in turn, provides enough heat in the digesters. However, with the implementation of heat exchangers, less heat would be needed in the reactors to reach pasteurisation temperature, so potentially the high energy-consuming filter belt can be eliminated.

5 Results and Discussion

The proposed improvements were divided into several stages of increasing complexity, each of which required investment and careful confirmation of the expected benefit before implementing the next one.

1. The simplest improvement (first stage) includes the implementation of one heat exchanger using the wasted heat of the process – the heat of the effluent discharged from the second reactor to effluent storage.

In practical numeric measurement, the findings of this study can be summarised as follows.

The results presented in [Chapter 4](#) show that a temperature shock resulting in a winter temperature drop of 8–10°C would normally be compensated for about 12–14 h. The proposed heat integration solution offers a 46% decrease in the temperature shock during winter and a 40% decrease in the same during summer, accompanied by shortening of reactor residence time (approximately by 5–6 h) and reducing the electricity required for mixing.

This can be estimated as a benefit related to the equivalent number of kilowatt hours savings of electrical energy for aeration and agitation, decreasing the energy required per tonne of product (digested sludge) by 7%.

The benefits of the proposed raw sludge preheating scheme are as follows:

- Increased operational temperature
- Thermophilic temperature in both reactors
- Flexibility to operational disturbances
- Shortened sludge treatment time
- Less aeration energy requirements per unit volume of produced biosolids
- Two reactors needed instead of four in summer: 100,000 kWh/year saving *versus*

operating and capital cost of an approximate 55 m² heat exchanger.

2. The second stage improvement includes the utilisation of the heat of the gas discharged from reactors and currently delivered to the Mona-shell absorber. This would lead to:
 - Residence time reduced by 11 h
 - Electrical energy for pretreatment – less 2 × 45 kW motors
 - Ignore pretreatment reactors (1a and 1b) – free for use as storage tanks
 - Flexibility improvement.
3. The third level of improvement would include the implementation of a storage tank as shown in [Fig. 4.5](#). Here additional investigations have to be performed in order to show whether any negative effect can be found from storing the discharged 15 m³ of sludge from the first reactor in the storage tank (ST, see [Fig. 4.5](#)) and after 2 × 30 min, transferring this amount from the storage tank to Reactor 2. This solution can be combined with the possibility of ignoring the second reactor as proposed earlier, following the satisfactory entrance of the thermophilic range of the first reactor.
4. If additional storage is installed to support the improvement from Stage 3 above, this would represent the fourth level of improvement, which would lead to doubling of the plant capacity. This would have to be explored further with designers, operation and plant management before the impact of such an improvement could be quantified. Continuing in this line of thinking this solution can be realised utilising the pretreatment reactors (1a and 1b) as storage tanks. The only investment in this case would be the need for reprogramming of the existing program for automatic control. At present this program has the ability to automatically redirect fluids from any

reactor to any other reactor, but is constrained in the particular order of the required transfer, otherwise the hardware (i.e. the physical piping and pumping facilities) is in place.

5.1 Additional Considerations (General and Specific)

One extra option for efficiency improvement could be related to the variable aeration control of the reactors. The aeration speed could be linked by a Programmable Logic Controller (PLC), such as simple time-controlled strategies, including running on full speed for a predetermined interval after batch feeding followed by a decrease in speed following the controlled oxidation level. Another option would be the control of aeration speed linked to the foam layer level, which requires a more sophisticated sensor.

Continuing to enumerate all possible engineering solutions addressing the energy efficiency improvement, we have also identified possibilities for the integration of other energy resources, including a significant heat loss contributor is the exhaust gas taken from the reactors and storage tanks. Further investigation of this source of heat is needed because of the link between the temperature of the gas and the absorption efficiency in the odour absorber.

In addition to the energy efficiency improvement measures presented above, based on heat integration supported retrofit-design, the following opportunities based on general engineering principles can be listed:

- Insulate the feed pipes to minimise heat loss
- Circulate the hot product through a heat exchanger coil in the feed tank to preheat the feed and reduce thermal shock
- Use a PLC to control the aeration level in the ATAD to prevent excess aeration
- Install a variable speed drive on pumps to control aeration
- A pre-storage tank can help to reduce the fluctuations of the sludge supplied to the reactors
- Use bypassing and over-design to deal with storm water and extra loads

- Electricity-consuming equipment – motors, pumps, solids-handling systems, blowers and mechanical aeration systems – to be carefully sized (aeration and pumping systems are the largest energy users)
- Reduce utility bills by taking advantage of time-shifting energy usage and controlling demand peaks (move high-energy consumption processes to lower night-time period)
- Preventive maintenance – as part of the energy management plan (under way in the Killarney plant).

5.2 Combined Management of Water and Energy

This option of plant efficiency improvement is one of the most promising and it can be placed at Stage 5 of future investigations. This is the desire for application of the systems approach at a much higher level of plant-wide investigation, i.e. study the potential for integration of waste-water treatment and sludge treatment sections of the plant:

- The returning to the anoxic zone should be from the end of the diffused air aeration system or the anoxic zone should be the last one in the series
- Insulation of the tanks would help improve the efficiency of treatment. The occasional cooling using the reactor jackets can be connected to the raw sludge preheating system
- Cooling water pumped from the final clarifiers to the reactors. The initial temperature of the water is $\sim 12^{\circ}\text{C}$ and the final temperature ranges from 24 to 30°C . The cooling effluent to be pumped to the ATAD at a rate of $8\text{ m}^3/\text{h}$
- In the wet ammonia scrubber, use effluent water instead of groundwater ($2\text{ m}^3/\text{h}$ and return it back to the head of works)
- Warm water should be pumped back to the WWTP, mixed with existing waste water to prevent a temperature shock.

6 Conclusions

This project has proved that the design of the ATAD system could be improved with the help of heat integration. The methodology adapted from large industrial processes and modified to be used for WWTPs provides guidelines for biological energy utilisation and energy efficiency improvement of the entire sludge treatment process.

The investigation demonstrated the applicability of the modified ATAD model to a full-scale plant.

The model's potential is not restricted to a tool for evaluation of process modifications from an energy efficiency perspective. Another objective could be to achieve more stable operation in response to short- and long-term disturbances.

The results of this work include:

- Changes in the plant operation schedule such as different configuration arrangements for greater energy efficiency
- More stable and steadier operation
- Reduced retention times, which also reduces the aeration and mixing energy – ultimately improving energy efficiency and reducing electricity needs for running the system.

Other potential options for achieving energy efficiencies include low potential heat available from the biosolids to be used elsewhere such as for heating of buildings around the WWTP.

This research deepened the understanding of the ATAD sludge treatment process and indicated areas of improvements for design and operation.

In academic terms, this project allows the following conclusions to be made:

- The process systems integration approach can be extended to deal with combined resources management – oxygen–water–energy transfer for efficiency management
- Flexibility and operability improvement are targeted; analysis and guided design changes are proposed
- A framework for efficient redesign is proposed, which includes electrical energy used in agitation and aeration, heat generation, and process heat recovery
- Positive side effects addressing environmental issues (e.g. odours, recycling of water, saving groundwater, etc.)
- The methodology sits well with a decision-assisting procedure advising a strategy for centralised/ decentralised waste-water treatment, accounting for the dynamics of the changeable processing environment
- An extended heat exchanger network synthesis task is formulated in the case of parametric fluctuations
- A combination of conceptual and mathematical approaches to energy integration supports different sides of planned improvement (the conceptual Pinch approach suggests the structure of the heat recovery system, while the mathematical approach evaluates the maximum heating and sizes of required heat exchangers)
- A start was made towards defining a new strategy for environmental impact analysis in dynamic conditions.

7 Future Work

The model calibration could be improved by employing reactor-specific values instead of using estimations. The sludge composition could also be checked by tests. The model could be used as a teaching tool as well as for process simulation and process control. The results obtained could be extended to dual treatment processes (aerobic combined with anaerobic).

The future plan to utilise this initial step in waste-water treatment improvement is related to model utilisation under the following scenarios:

- Simulate the effect of a modified feeding process (patterns) on reaction rates and on the percentage reduction of volatile solids
- Simulate the case of combined heat integration and feeding patterns modification
- Formulate the optimisation task including the mathematical model of the entire system – the heat integration and the reactor models
- Formulate and solve a heterogeneous synthesis task, where the reactor numbers, volumes and connection structure are optimisation variables together with the number, sizes and topology of the heat integration system.

A PhD student to continue this work was recruited in October 2007 under the Charles Parsons Award and the first results in continuation of this work are expected soon.

8 References

- Batts, D., Seiders, K. and Johnson, A., 1993. *Demand Side Management Opportunities in the Wastewater Industry*. Water Environment Federation, Proceedings of the 66th Annual Conference & Exposition.
- Deeny, K., Hahn, H., Leonhard, D. and Heidman, J., 1991. Autoheated thermophilic aerobic digestion. *Water Environment and Technology* **3(10)**: 65–72.
- Gomez, J., de Gracia, M., Ayesa, E. and Garcia-Heras, J.L., 2007. Mathematical modelling of autothermal thermophilic aerobic digesters. *Water Research* **41(5)**: 959–968.
- Ivanov, B., Peneva, K. and Bancheva, N., 1993. Heat integration in batch reactors operating in different time intervals. Part III. Synthesis and reconstruction of integrated systems with heat tanks. *Hungarian Journal of Industrial Chemistry* **21**: 217–223.
- Kelly, H.G. and Warren, R., 1997. *Autothermal Thermophilic Aerobic Digestion Design*. CSCE/ASCE Environmental Engineering Conference, Edmonton, AB, Canada, July 22–26, pp. 217–225.
- Kovacs, R., Mihaltz, P. and Csikor, Zs., 2007. Kinetics of autothermal thermophilic aerobic digestion-application and extension of Activated Sludge Model No. 1 at thermophilic temperatures, Turkey.
- Rulkens, W.H., 2003. Sustainable sludge management – what are the challenges for the future. *Biosolids 2003: Wastewater Sludge as a Resource*. International Water Association (IWA) Conference, 23–25 June 2003.
- Stentiford, E.I., 2001, Sludge treatment options: aerobic digestion. In: Spinosa, L and Vesilind, P.A. (Eds) *Sludge into Biosolids: Processing, Disposal, Utilization*. IWA Publishing, pp. 209–222.
- Tchobanoglous, G., Burton, F.L. and Stensel, H.D., 2003. *Wastewater Engineering: Treatment and Reuse*. Metcalf & Eddy, Inc., Fourth Edition, McGraw-Hill, USA.
- US EPA, 2003. *Environmental Regulations and Technology. Control of Pathogens and Vector Attraction in Sewage Sludge*. Under 40 CFR Part 503. EPA Report, Cincinnati, OH 45268, USA.

The results of this project were reported at the following scientific events:

- Brzyszc, B., 2007. Energy efficiency improvement of anaerobic wastewater treatment processes using process integration techniques. *Environment* **25**: 137.
- Jamniczky-Kaszás, D., Zhelev, T., O'Regan, B. and Moles, R., 2007. Energy efficiency improvement of wastewater treatment processes using process integration techniques. *Environment* **21**: 133.
- Zhelev, T.K., Layden, N., Pembroke, T. and Bartlett, J., 2006. *Energy Efficiency Improvement of Wastewater Treatment Processes Subjected to Load Fluctuations*. ChISA 2006, G3-04, 1023.
- Zhelev, T., Vaklieva-Bancheva, N. and Jamniczky-Kaszás, D., 2008. About energy efficiency improvement of auto-thermal thermophilic aerobic digestion processes. *Computer Aided Chemical Engineering* **25**: 1–6. (Elsevier, ISBN: 978-0-444-53228-2, Topic 6: CAPE and Society.)

Abbreviations

| | | | |
|------|--|------|-------------------------------|
| ATAD | Autothermal Thermophilic Aerobic Digestion | PLC | Programmable Logic Controller |
| EPA | Environmental Protection Agency | WWTP | Waste-Water Treatment Plant |

An Gníomhaireacht um Chaomhnú Comhshaoil

Is í an Gníomhaireacht um Chaomhnú Comhshaoil (EPA) comhlachta reachtúil a chosnaíonn an comhshaoil do mhuintir na tíre go léir. Rialaímid agus déanaimid maoirsiú ar ghníomhaíochtaí a d'fhéadfadh truailliú a chruthú murach sin. Cinntímid go bhfuil eolas cruinn ann ar threochtaí comhshaoil ionas go nglactar aon chéim is gá. Is iad na príomh-nithe a bhfuilimid gníomhach leo ná comhshaoil na hÉireann a chosaint agus cinntiú go bhfuil forbairt inbhuanaithe.

Is comhlacht poiblí neamhspleách í an Gníomhaireacht um Chaomhnú Comhshaoil (EPA) a bunaíodh i mí Iúil 1993 faoin Acht fán nGníomhaireacht um Chaomhnú Comhshaoil 1992. Ó thaobh an Rialtais, is í an Roinn Comhshaoil agus Rialtais Áitiúil a dhéanann urraíocht uirthi.

ÁR bhFREAGRACHTAÍ

CEADÚNÚ

Bíonn ceadúnais á n-eisiúint againn i gcomhair na nithe seo a leanas chun a chinntiú nach mbíonn astuithe uathu ag cur sláinte an phobail ná an comhshaoil i mbaol:

- áiseanna dramhaíola (m.sh., líonadh talún, loisceoirí, stáisiúin aistriúcháin dramhaíola);
- gníomhaíochtaí tionsclaíocha ar scála mór (m.sh., déantúsaíocht cógaisíochta, déantúsaíocht stroighne, stáisiúin chumhachta);
- diantalmhaíocht;
- úsáid faoi shrian agus scaoileadh smachtaithe Orgánach Géinathraithe (GMO);
- mór-áiseanna stórais peitreal.

FEIDHMIÚ COMHSHAOIL NÁISIÚNTA

- Stiúradh os cionn 2,000 iniúchadh agus cigireacht de áiseanna a fuair ceadúnas ón nGníomhaireacht gach bliain.
- Maoirsiú freagrachtaí cosanta comhshaoil údarás áitiúla thar sé earnáil - aer, fuaim, dramhaíl, dramhuisce agus caighdeán uisce.
- Obair le húdaráis áitiúla agus leis na Gardaí chun stop a chur le gníomhaíocht mhídhleathach dramhaíola trí chomhordú a dhéanamh ar líonra forfheidhmithe náisiúnta, díriú isteach ar chiontóirí, stiúradh fiosrúcháin agus maoirsiú leigheas na bhfadhbanna.
- An dlí a chur orthu siúd a bhriseann dlí comhshaoil agus a dhéanann dochar don chomhshaoil mar thoradh ar a ngníomhaíochtaí.

MONATÓIREACHT, ANAILÍS AGUS TUAIRISCIÚ AR AN GCOMHSHAOIL

- Monatóireacht ar chaighdeán aer agus caighdeán aibhneacha, locha, uisce taoide agus uisce talaímh; leibhéil agus sruth aibhneacha a thomhas.
- Tuairiscíú neamhspleách chun cabhrú le rialtais náisiúnta agus áitiúla cinntiú a dhéanamh.

RIALÚ ASTUITHE GÁIS CEAPTHA TEASA NA HÉIREANN

- Caínníochtú astuithe gáis ceaptha teasa na hÉireann i gcomhthéacs ár dtiomantas Kyoto.
- Cur i bhfeidhm na Treorach um Thrádáil Astuithe, a bhfuil baint aige le hos cionn 100 cuideachta atá ina mór-ghineadóirí dé-ocsaíd charbóin in Éirinn.

TAIGHDE AGUS FORBAIRT COMHSHAOIL

- Taighde ar shaincheisteanna comhshaoil a chomhordú (cosúil le caighdeán aer agus uisce, athrú aeráide, bithéagsúlacht, teicneolaíochtaí comhshaoil).

MEASÚNÚ STRAITÉISEACH COMHSHAOIL

- Ag déanamh measúnú ar thionchar phleananna agus chláracha ar chomhshaoil na hÉireann (cosúil le plannanna bainistíochta dramhaíola agus forbartha).

PLEANÁIL, OIDEACHAS AGUS TREOIR CHOMHSHAOIL

- Treoir a thabhairt don phobal agus do thionscal ar cheisteanna comhshaoil éagsúla (m.sh., iarratais ar cheadúnais, seachaint dramhaíola agus rialacháin chomhshaoil).
- Eolas níos fearr ar an gcomhshaoil a scaipeadh (trí cláracha teilifíse comhshaoil agus pacáistí acmhainne do bhunscoileanna agus do mheánscoileanna).

BAINISTÍOCHT DRAMHAÍOLA FHORGHNÍOMHACH

- Cur chun cinn seachaint agus laghdú dramhaíola trí chomhordú An Chláir Náisiúnta um Chos Dramhaíola, lena n-áirítear cur i bhfeidhm na dTionscnamh Freagrachta Táirgeoirí.
- Cur i bhfeidhm Rialachán ar nós na treoracha maidir le Trealamh Leictreach agus Leictreonach Caite agus le Srianadh Substaintí Guaiseacha agus substaintí a dhéanann ídiú ar an gcrios ózóin.
- Plean Náisiúnta Bainistíochta um Dramhaíl Ghuaiseach a fhorbairt chun dramhaíl ghuaiseach a sheachaint agus a bhainistiú.

STRUCHTÚR NA GNÍOMHAIREACHTA

Bunaíodh an Gníomhaireacht i 1993 chun comhshaoil na hÉireann a chosaint. Tá an eagraíocht á bhainistiú ag Bord lánaimseartha, ar a bhfuil Príomhstíúrthóir agus ceithre Stíúrthóir.

Tá obair na Gníomhaireachta ar síúl trí ceithre Oifig:

- An Oifig Aeráide, Ceadúnaithe agus Úsáide Acmhainní
- An Oifig um Fhorfheidhmiúchán Comhshaoil
- An Oifig um Measúnacht Comhshaoil
- An Oifig Cumarsáide agus Seirbhísí Corparáide

Tá Coiste Comhairleach ag an nGníomhaireacht le cabhrú léi. Tá dáréag ball air agus tagann siad le chéile cúpla uair in aghaidh na bliana le plé a dhéanamh ar cheisteanna ar ábhar íad agus le comhairle a thabhairt don Bhord.

Science, Technology, Research and Innovation for the Environment (STRIVE) 2007-2013

The Science, Technology, Research and Innovation for the Environment (STRIVE) programme covers the period 2007 to 2013.

The programme comprises three key measures: Sustainable Development, Cleaner Production and Environmental Technologies, and A Healthy Environment; together with two supporting measures: EPA Environmental Research Centre (ERC) and Capacity & Capability Building. The seven principal thematic areas for the programme are Climate Change; Waste, Resource Management and Chemicals; Water Quality and the Aquatic Environment; Air Quality, Atmospheric Deposition and Noise; Impacts on Biodiversity; Soils and Land-use; and Socio-economic Considerations. In addition, other emerging issues will be addressed as the need arises.

The funding for the programme (approximately €100 million) comes from the Environmental Research Sub-Programme of the National Development Plan (NDP), the Inter-Departmental Committee for the Strategy for Science, Technology and Innovation (IDC-SSTI); and EPA core funding and co-funding by economic sectors.

The EPA has a statutory role to co-ordinate environmental research in Ireland and is organising and administering the STRIVE programme on behalf of the Department of the Environment, Heritage and Local Government.