

STRIVE

Report Series No.112

Regional-Scale Assessment of Submarine Groundwater Discharge Using Remote Sensing

STRIVE

Environmental Protection
Agency Programme

2007-2013

Environmental Protection Agency

The Environmental Protection Agency (EPA) is a statutory body responsible for protecting the environment in Ireland. We regulate and police activities that might otherwise cause pollution. We ensure there is solid information on environmental trends so that necessary actions are taken. Our priorities are protecting the Irish environment and ensuring that development is sustainable.

The EPA is an independent public body established in July 1993 under the Environmental Protection Agency Act, 1992. Its sponsor in Government is the Department of the Environment, Community and Local Government.

OUR RESPONSIBILITIES

LICENSING

We license the following to ensure that their emissions do not endanger human health or harm the environment:

- waste facilities (e.g., landfills, incinerators, waste transfer stations);
- large scale industrial activities (e.g., pharmaceutical manufacturing, cement manufacturing, power plants);
- intensive agriculture;
- the contained use and controlled release of Genetically Modified Organisms (GMOs);
- large petrol storage facilities;
- waste water discharges;
- dumping at sea.

NATIONAL ENVIRONMENTAL ENFORCEMENT

- Conducting over 1200 audits and inspections of EPA licensed facilities every year.
- Overseeing local authorities' environmental protection responsibilities in the areas of - air, noise, waste, waste-water and water quality.
- Working with local authorities and the Gardaí to stamp out illegal waste activity by co-ordinating a national enforcement network, targeting offenders, conducting investigations and overseeing remediation.
- Prosecuting those who flout environmental law and damage the environment as a result of their actions.

MONITORING, ANALYSING AND REPORTING ON THE ENVIRONMENT

- Monitoring air quality and the quality of rivers, lakes, tidal waters and ground waters; measuring water levels and river flows.
- Independent reporting to inform decision making by national and local government.

REGULATING IRELAND'S GREENHOUSE GAS EMISSIONS

- Quantifying Ireland's emissions of greenhouse gases in the context of our Kyoto commitments
- Implementing the Emissions Trading Directive, involving over 100 companies who are major generators of carbon dioxide in Ireland.

ENVIRONMENTAL RESEARCH AND DEVELOPMENT

- Co-ordinating research on environmental issues (including air and water quality, climate change, biodiversity, environmental technologies).

STRATEGIC ENVIRONMENTAL ASSESSMENT

- Assessing the impact of plans and programmes on the Irish environment (such as waste management and development plans).

ENVIRONMENTAL PLANNING, EDUCATION AND GUIDANCE

- Providing guidance to the public and to industry on various environmental topics (including licence applications, waste prevention and environmental regulations).
- Generating greater environmental awareness (through environmental television programmes and primary and secondary schools' resource packs).

PROACTIVE WASTE MANAGEMENT

- Promoting waste prevention and minimisation projects through the co-ordination of the National Waste Prevention Programme, including input into the implementation of Producer Responsibility Initiatives.
- Enforcing Regulations such as Waste Electrical and Electronic Equipment (WEEE) and Restriction of Hazardous Substances (RoHS) and substances that deplete the ozone layer.
- Developing a National Hazardous Waste Management Plan to prevent and manage hazardous waste.

MANAGEMENT AND STRUCTURE OF THE EPA

The organisation is managed by a full time Board, consisting of a Director General and four Directors.

The work of the EPA is carried out across four offices:

- Office of Climate, Licensing and Resource Use
- Office of Environmental Enforcement
- Office of Environmental Assessment
- Office of Communications and Corporate Services

The EPA is assisted by an Advisory Committee of twelve members who meet several times a year to discuss issues of concern and offer advice to the Board.

EPA STRIVE Programme 2007–2013

Regional-Scale Assessment of Submarine Groundwater Discharge Using Remote Sensing

**Development of Remote Sensing as a Tool for Detection, Quantification
and Evaluation of Submarine Groundwater Discharge (SGD) to
Irish Coastal Waters**

(2008-FS-W-4-S5)

STRIVE Report

End of Project Report available for download on <http://erc.epa.ie/safer/reports>

Prepared for the Environmental Protection Agency

by

Biogeochemistry Research Group, Trinity College Dublin

Authors:

Jean Wilson and Carlos Rocha

ENVIRONMENTAL PROTECTION AGENCY

An Ghníomhaireacht um Chaomhnú Comhshaoil
PO Box 3000, Johnstown Castle, Co. Wexford, Ireland

Telephone: +353 53 916 0600 Fax: +353 53 916 0699

Email: info@epa.ie Website: www.epa.ie

ACKNOWLEDGEMENTS

This report is published as part of the Science, Technology, Research and Innovation for the Environment (STRIVE) Programme 2007–2013. The programme is financed by the Irish Government under the National Development Plan 2007–2013. It is administered on behalf of the Department of the Environment, Community and Local Government by the Environmental Protection Agency which has the statutory function of co-ordinating and promoting environmental research.

Funding for this project was gratefully provided through a 3-year Research Fellowship awarded via the EPA STRIVE 2007–2013 programme, hosted by the Biogeochemistry Research Group, School of Natural Sciences, Trinity College Dublin.

DISCLAIMER

Although every effort has been made to ensure the accuracy of the material contained in this publication, complete accuracy cannot be guaranteed. Neither the Environmental Protection Agency nor the author(s) accept any responsibility whatsoever for loss or damage occasioned or claimed to have been occasioned, in part or in full, as a consequence of any person acting, or refraining from acting, as a result of a matter contained in this publication. All or part of this publication may be reproduced without further permission, provided the source is acknowledged.

The EPA STRIVE Programme addresses the need for research in Ireland to inform policymakers and other stakeholders on a range of questions in relation to environmental protection. These reports are intended as contributions to the necessary debate on the protection of the environment.

EPA STRIVE PROGRAMME 2007–2013

Published by the Environmental Protection Agency, Ireland

ISBN: 978-1-84095-510-1

Price: Free

Online version

Details of Project Partners

Dr Jean Wilson (Project Co-ordinator)

Department of Geography
School of Natural Sciences
Centre for the Environment
Trinity College Dublin
Dublin 2
Ireland
Tel.: +353 1 8961121
Email: jewilson@tcd.ie

Dr Carlos Rocha (Project Supervisor)

Department of Geography
School of Natural Sciences
Centre for the Environment
Trinity College Dublin
Dublin 2
Ireland
Tel.: +353 1 8963871
Email: rochac@tcd.ie

Table of Contents

<u>Acknowledgements</u>	<u>ii</u>
<u>Disclaimer</u>	<u>ii</u>
<u>Details of Project Partners</u>	<u>iii</u>
<u>Executive Summary</u>	<u>vii</u>
<u>1 Introduction</u>	<u>1</u>
<u>1.1 Overview</u>	<u>1</u>
<u>1.2 Project Goals and Objectives</u>	<u>2</u>
<u>1.3 Conclusion</u>	<u>2</u>
<u>2 Theoretical Background</u>	<u>3</u>
<u>2.1 Remote Sensing for Detection, Quantification and Evaluation of SGD</u>	<u>3</u>
<u>2.2 Geochemical Tracers for SGD Detection and Analysis</u>	<u>4</u>
<u>2.3 Conclusion</u>	<u>5</u>
<u>3 Methodology</u>	<u>6</u>
<u>3.1 Introduction</u>	<u>6</u>
<u>3.2 Remote Sensing Techniques for SGD Detection and Analysis</u>	<u>7</u>
<u>3.3 Geochemical Tracing I: A Case Study of Hook Head, Co. Wexford</u>	<u>7</u>
<u>3.4 Geochemical Tracing II: A Case Study of Kinvarra Bay, Co. Galway</u>	<u>10</u>
<u>4 Results and Discussion</u>	<u>14</u>
<u>4.1 Thermal Image Analysis</u>	<u>14</u>
<u>4.2 Geochemical Tracing I: A Case Study of Hook Head, Co. Wexford</u>	<u>18</u>
<u>4.3 Geochemical Tracing II: A Case Study of Kinvarra, Co. Galway</u>	<u>25</u>
<u>4.3.1 Estimating water residence times using the radium quartet</u>	<u>30</u>
<u>5 Conclusions and Recommendations</u>	<u>33</u>
<u>5.1 Application of Remote Sensing in the Detection, Quantification and Evaluation of SGD</u>	<u>33</u>
<u>5.2 Geochemical Tracing Techniques for SGD Assessment, Quantification and Evaluation</u>	<u>34</u>
<u>References</u>	<u>36</u>
<u>Acronyms and Annotations</u>	<u>40</u>

Executive Summary

Submarine groundwater discharge (SGD) is defined broadly as any and all flow of water from land to the ocean across the seabed. Groundwater in transit from land to sea can become contaminated with a variety of substances, including nutrients, heavy metals and other dissolved substances. SGD is receiving considerable attention in the literature as a major pathway for freshwater and anthropogenic pollutants to coastal waters. SGD inputs could be a significant source of contaminants to Irish coastal waters, with implications for the type and extent of monitoring required to fulfil the terms of the Water Framework Directive. Despite acknowledgement of its potential impact on coastal ecosystem functioning, SGD remains a poorly understood and often overlooked process when implementing coastal monitoring and management programmes. For instance, European Union directives aimed at improving the quality of the water environment do not acknowledge SGD as a potential nutrient source for assessment or monitoring. This is because the spatially and temporally heterogeneous nature of groundwater discharge renders locating and quantifying rates of SGD an appreciable challenge. In recognition of both the significance of groundwater discharge as a potential source of contamination and the challenges to locating and quantifying the contribution of groundwater discharge to the coastal zone, a comprehensive cost-effective methodology to facilitate a regional assessment of SGD formed the central focus of this fellowship, using Ireland, specifically Kinvarra Bay, Co. Galway, Hook Head, Co. Wexford and Lough Mask, Co. Mayo, as case-study locations.

Recent advances in remote sensing provide an affordable tool with which to evaluate contamination of coastal waters from SGD. Temperature has been used successfully to study groundwater discharge by comparing the relatively constant temperature of groundwater with that of surface waters which fluctuate with season. Using freely available medium-resolution satellite imagery acquired during summer months, clearly discernible anomalous cold-water plumes were

revealed to be emanating from nearshore waters at over 35 locations around the coastline of Ireland. The plumes constitute the dominant sea surface temperature feature observed from a selection of temperature maps derived from 60-m resolution Landsat Enhanced Thematic Mapper Plus thermal infrared images. Potential sites of SGD were linked to geological features on land acting as possible sources by combining within a Geographical Information System-mapped temperature anomalies with ancillary onshore spatial data sets describing bedrock geology including aquifer fault lines. Geochemical tracing undertaken to determine the spatial distribution of radon and salinity on surface waters was completed to both verify the remote sensing results as to the presence of SGD (as radon is found in significantly higher concentrations in discharging groundwater relative to the sea) and to provide qualitative and subsequent assessments of sources and flow rates.

Elevated radon activities confirmed the presence of SGD and concurrent salinity measurements facilitated a qualitative assessment of potential sources where, for example at Hook Head, the estuary was eliminated as the primary origin of the excess radon measured during the nearshore surveys. To quantify groundwater discharge rates, a radon mass balance approach was adopted and concurrent nutrient analysis was undertaken to determine whether SGD is a significant pollution source. Results from the tidal sampling campaign undertaken at Kinvarra clearly illustrate how peaks in radon activity levels were accompanied by a substantial freshening and cooling of previously saline nearshore waters associated with low tide, as illustrated through the continuous conductivity and temperature data. Moreover, concurrent nutrient measurements explicitly linked the magnitude and variation of nitrate and silicate levels to groundwater discharge.

Remote sensing and geochemical tracing tools developed as part of this project are not limited to the study area or the coast but can also be directly applied to a national assessment of lake systems. Cool

groundwater discharges from the eastern shorelines of Lough Mask were clearly visible in the temperature maps. The spatial distribution of radon matched the results from the thermal image analysis and areas of elevated radon activities along the north and eastern margins of the lake coincided spatially with the

presence of large cold water plumes confirming the presence of SGD. In summary, this research comprises the integration of remote sensing and geochemical tracing techniques for detection, quantification and evaluation of SGD to and associated contaminants of Irish coastal waters.

1 Introduction

1.1 Overview

Submarine groundwater discharge (SGD) is defined broadly as any and all flow of water across the seabed from land to sea (Burnett et al., 2001) and encompasses several components of subsurface flow, including terrestrial freshwater and recirculated seawater (Moore, 1999). Groundwater will seep persistently into the sea through permeable sediments wherever an aquifer with positive head relative to sea level is hydraulically connected to a surface water body (Johannes, 1980). Accordingly, SGD is a ubiquitous feature of coastlines worldwide. It is extremely variable both spatially and temporally but occurs predominately in the form of nearshore seepage, offshore seepage and submarine springs (Burnett et al., 2001). Submarine seepage occurring offshore is generally related to extensive networks of underground caves and channels, including local fracture systems (Shaban et al., 2005) that facilitate the transport of groundwater from land aquifers to points several kilometres away from the shoreline.

Groundwater in transit from land to sea can become contaminated with a variety of substances, including nutrients and heavy metals (Swarzenski et al., 2007; Lee et al., 2009); hence, SGD has been defined in the literature as a potentially significant source and pathway of nutrients, dissolved substances and diffuse pollution to coastal areas, particularly when originating from contaminated continental aquifers (Leote et al., 2008). While fresh groundwater discharge is considered to be less than 10% of the total freshwater flux to the ocean, the inputs of associated nutrients and contaminants may be far more significant because concentrations in groundwater often exceed that of surface waters (Slomp and Van Cappellen, 2004). Therefore, relatively small groundwater discharge rates can deliver comparatively large quantities of solutes, including nutrients, to coastal areas. For example, nutrient supply via SGD has been linked to eutrophication and suggested as a potential precursor of harmful algal blooms (Hu et al., 2006; Lee and Kim,

2007) or increased bacterial concentrations (Boehm et al., 2004).

Despite acknowledgement of its potential impact on coastal ecosystem functioning, SGD remains a poorly understood and often overlooked process when implementing coastal monitoring and management programmes. For instance, European Union (EU) directives, such as the Water Framework Directive (WFD) (2000/60/EC) aimed at improving the quality of the water environment, do not acknowledge SGD as a potential nutrient source for assessment or monitoring. This is because the spatially and temporally heterogeneous nature of groundwater discharge from an essentially invisible source renders locating and quantifying rates of SGD an appreciable challenge. Consequently, the quantitative distinction between SGD and easily gauged surface run-off sources may be impaired when implementing coastal management policy based on current nutrient monitoring programmes, for example.

In recognition of both the significance of groundwater discharge as a potential source of contamination and the challenges to locating and quantifying the contribution of groundwater discharge to the coastal zone, a comprehensive cost-effective methodology to facilitate a regional assessment of SGD is presented here, using Ireland, specifically Kinvarra Bay, Co. Galway, and Hook Head, Co. Wexford, as case-study locations. This work is based on the premise that relatively cool groundwater discharging to warmer coastal waters manifests in the thermal band (Band 6) of Landsat Enhanced Thematic Mapper Plus (ETM+) satellite imagery acquired during summer months. The overarching goal of this study, the first of its kind in Ireland, was to identify and characterise locations of SGD through the integration of satellite thermal remote sensing (Landsat ETM+ thermal infrared (TIR)), ancillary geological and hydrogeological data and geochemical tracing (radon-222, salinity) techniques (Wilson and Rocha, 2012).

1.2 Project Goals and Objectives

Specifically this research asked:

- Could SGD be successfully mapped and quantified using remotely sensed imagery?
- What is the terrestrial (non-oceanic) groundwater fraction of SGD and does it represent a significant source of pollution for the study areas identified?
- How important is SGD and to what extent should it be accounted for as a potential coastal pressure source when implementing water and land resource management policies in line with the WFD?

In summary, the objectives of this research were to:

- Evaluate the potential of remote sensing in SGD assessment in Ireland and validate the areas of SGD identified using TIR imagery in the field
- Identify the geologic, hydrogeologic and anthropogenic controls on SGD through an analysis of available national offshore and onshore geological spatial data sets (e.g.

Geological Survey of Ireland (GSI) and Environmental Protection Agency (EPA)) within a Geographical Information System (GIS);

- Determine the significance of anthropogenically derived nutrients within SGD; and
- Correlate findings, where possible, with previous knowledge of contamination and eutrophication risks already established for coastal areas in Ireland.

1.3 Conclusion

Remote sensing and geochemical tracing tools developed as part of this project are not limited to the study area or coast but can be directly applied to a national assessment of SGD, with potential application to lake systems also. This synthesis report provides a short summary of the project outcomes, including the development of a cost-effective remote sensing methodology to detect potential SGD sites and the combined application of geochemical tracing to provide a qualitative and quantitative evaluation of SGD of three case study locations where land–sea fluxes are shown to occur.

2 Theoretical Background

2.1 Remote Sensing for Detection, Quantification and Evaluation of SGD

Recognition that SGD is an important pathway for freshwater, associated nutrients, contaminants and other materials to nearshore marine environments necessitates the development of tools that will facilitate regional coastal zone assessments. Recent advances in remote sensing provide an affordable tool with which to evaluate contamination of coastal waters from SGD and tools that can simplify the increasingly complicated task of resource management for coastal managers are invaluable.

Remote sensing methods for SGD detection are applicable wherever temperature gradients form between coastal marine waters and discharging terrestrial groundwater. As water is almost opaque in the TIR, thermal remote sensing of surface water temperatures only provides spatially distributed values of radiant temperature in the 'skin' layer or top 100 μm of the water column (Handcock et al., 2006). Temperature has been used successfully to study groundwater discharge by comparing the relatively constant temperature of groundwater with that of surface waters which fluctuate with season (Dale and Miller, 2007). In general, groundwater between approximately 5-m and 100-m depths maintains a nearly constant temperature of 1–2°C higher than mean annual air temperature (Anderson, 2004).

The utility and importance of temperature as a tracer for SGD depend upon whether a detectable difference exists between the temperatures of discharging groundwater and nearshore coastal waters. The sensitivity of a detector of thermal radiation is a measure of noise equivalent temperature difference (NETD), which is the minimum temperature difference detectable by the sensor and varies between remote sensing systems and platforms (Handcock et al., 2006). Medium-resolution satellite sensors, such as Landsat ETM+, Terra-MODIS and ASTER, have NETDs of 0.22°C (Barsi et al., 2003), 0.05°C (Barnes

et al., 1998) and 0.3°C (Gillespie et al., 1998), respectively.

Daily observations of both regional and global sea surface temperature (SST) (Kilpatrick et al., 2001; Parkinson, 2003) provide, for example, direct insight into the spatial and temporal variability of upper ocean currents, water mass boundaries and mixing (Thomas et al., 2002). This is an established practice in oceanography: ocean temperatures have been studied extensively since the late 1970s from a variety of satellite sensors (Menzel and Purdom, 1994; Esaias et al., 1998; Abrams, 2000; Fox et al., 2005; Corlett et al., 2006). While global measurements of SST gathered by these satellites facilitate effective observations of ocean-basin-scale circulation patterns, the relatively coarse spatial resolutions of these sensors (=1 km) will not resolve fine-scale SST gradients important for the study of oceanographic features of nearshore coastal zones (Fisher and Mustard, 2004). Indeed, a spatial resolution of 1 km is not sufficient to discriminate thermal gradients in water bodies less than 3 km in width or water masses located less than 2 km from the shoreline (Wloczyk et al., 2006). However, satellite sensors with spatial resolutions appropriate for tracking small-scale thermal patterns, such as Landsat (Gibbons and Wukelic, 1989; Tcherepanov et al., 2005), are limited by both their spectral and temporal resolution. For example, atmospheric correction of surface temperature values generated from image data requires at least two thermal bands (Wloczyk et al., 2006) and, as both Landsat Thematic Mapper (TM) and ETM+ record thermal emissivity in one waveband with a repeat cycle of 16 days, inherent atmospheric correction and resolution of temporal variability on scales shorter than seasonal are precluded (Thomas et al., 2002). Moreover, an error with the scan-line corrector (SLC) aboard the ETM+ sensor means that post-May 2003 images include large data gaps and consequently some of the available archived images may be unusable. While an obvious solution to the problem of low spatial, spectral and temporal resolution associated with medium-resolution satellite

systems is to use airborne systems, these tend to be extremely costly and economically unsuitable for a regional-scale assessment of potential SGD locations. The application of Landsat TIR for SST retrieval is neither extensive nor widespread and, although far less frequently reported, satellite-derived SSTs have been applied with limited success to identify and characterise coastal SGD (Wang et al., 2008; Varma et al., 2010).

Remote sensing can be used to detect SGD by examining the thermal signature of discharging groundwater but, to actually confirm the presence and occurrence of SGD at the sites identified, the thermal anomalies observed within the satellite imagery as a signal for SGD must be verified.

2.2 Geochemical Tracers for SGD Detection and Analysis

Natural tracers of SGD, other than temperature, include salinity and radioisotopes (e.g. radon-222 (^{222}Rn) and the radium quartet radium-223, -224, -226 and -228 (^{223}Rn , ^{224}Rn , ^{226}Rn , ^{228}Rn), which must be greatly enriched in the discharging groundwater relative to the coastal ocean to provide a detectable signal. The use of salinity as a groundwater tracer was pioneered by Johannes (1980) and has been used with success to trace SGD (Beck et al., 2007). However, groundwater discharge to the coastal ocean may not be accompanied by a discernible freshening of receiving coastal waters. In fact SGD may include a major portion of recirculated seawater and the effects of dilution, for example, may overshadow its nature as a tracer. Additionally, observed salinity differences could be the result of other freshwater inputs to the marine environment such as surface water discharge.

Research reports that naturally occurring radioisotopes can be successfully applied to indicate the sources and quantify the fluxes of SGD to the coastal ocean (Corbett et al., 1999; Moore, 1999; Charette et al., 2001; Burnett and Dulaiova, 2003; Hwang et al., 2005; Felipe et al., 2007; Kim et al., 2008; Povinec et al., 2008; Lee et al., 2009). To provide a detectable signal, however, the groundwater tracer must be greatly enriched in the discharging groundwater relative to the coastal ocean. Radon (Rn)

and the radium (Ra) quartet originate from the decay of uranium and thorium radioisotopes that are present in most rocks. The isotopic signature for radon and radium isotopes in a given source of water will be a function of several factors such as contact time with geological materials and salinity (Lamontagne et al., 2008).

^{222}Rn is an ideal tracer of SGD as it behaves conservatively (as a noble gas), is relatively easy to measure, its concentration in groundwater is several orders of magnitude higher than in seawater and its half-life of 3.82 days is comparable with the scale of coastal circulation (Cable et al., 1997; Dulaiova et al., 2008; Stieglitz et al., 2010). ^{222}Rn alpha-decays to polonium (^{218}Po) with a half-life of 3.8 days, which in turn decays to ^{214}Po with a half-life of 3 min (Stieglitz, 2005). According to Stieglitz et al. (2010), the amount of radon present in seawater depends on a number of factors, principally upon the rates of seawater pumping, radon activity levels within discharging river water and groundwater, the production rate of sea-floor sediments, water depth and offshore mixing. Radon activities decrease due to gaseous exchange with the atmosphere and radioactive decay when groundwater containing radon discharges to surface water. When groundwater discharges to the ocean, a decrease in radioactivity occurs due to mixing with open ocean water, where radon concentrations are low. Continuous radon sampling along a coastline can be used as an indicator for the presence of SGD (Dulaiova et al., 2005; Stieglitz, 2005; Burnett et al., 2008). Moreover, continuous mapping of radon in combination with ocean water salinity can be used to infer and interpret locations of radon input to the ocean (Stieglitz et al., 2010). Excess ^{222}Rn (i.e. amount of radon unsupported by ^{226}Ra) has been used to successfully identify and quantify groundwater fluxes into freshwater bodies (Corbett et al., 2000), estuaries (Hussain et al., 1999) and the coastal ocean (Dulaiova et al., 2008). Once radon fluxes are estimated, assessed fluxes can include diffusive input from sediment, surface water advection, air-sea evasion, groundwater input and radioactive decay (Schwartz, 2003). SGD can be calculated by dividing the fluxes by the radon concentration of the groundwater (Burnett and Dulaiova, 2006).

Radium is largely particle bound in fresh water but will desorb from particles in contact with salty water as the ionic strength of groundwater increases with increasing salinity. Radium isotope activities are often several orders of magnitude higher than in either fresh surface water or ocean water (Michael et al., 2011), and radium is particularly useful for SGD studies where subsurface mixing of fresh water and seawater occurs. Sources of water with an exposure to geologic materials in the range of hours to days will tend to be more enriched in the short-lived ^{223}Ra (half-life 11.4 days) and ^{224}Ra (half-life = 3.66 days) relative to the long-lived ^{226}Ra (half-life = 1,600 years) and ^{228}Ra (half-life = 5.75 years) due to the rapid regeneration of short-lived radium activity (Hancock and Murray, 1996). These short-lived isotopes are found in higher concentrations close to continental margins and are depleted in open oceans (Povinec et al., 2008) and can be used to assess water residence time (Moore, 2000). Conversely, sources of water with longer exposure to geologic materials (over the range of years to millennia) will be more enriched in the longer-lived radium isotopes (Rama and Moore, 1996). The difference in regeneration rates results in differences in fluxes of each of these isotopes. The fluxes are sustained from all input sources, including rivers,

surface run-off, sediments and SGD. The distribution of the short-lived isotopes ^{223}Ra and ^{224}Ra can be used to estimate the mixing coefficients (Moore, 2000), which in turn can be used to calculate the offshore flux of ^{226}Ra . Assuming that the radium gradients are steady state (i.e. over the timescale of the mixing processes), all radium sources are accounted for and excess radium is supplied by SGD near the coast; groundwater discharge can be estimated by dividing the radium flux by the concentration of radium in the groundwater (Burnett et al., 2008; Lamontagne et al., 2008).

2.3 Conclusion

The use of temperature, salinity and radioisotopes, specifically ^{222}Rn and the radium quartet (^{223}Ra , ^{224}Ra , ^{226}Ra and ^{228}Ra), is well documented in the literature as successful tracers of SGD to coastal waters. Moreover, the techniques are not limited to SGD detection and quantification at the coast but can be applied to freshwater systems. In this study, for the first time in Ireland, a tiered methodology combining remote sensing and geochemical tracing is presented within the context of two case-study locations to detect and quantify groundwater and associated nutrients discharging to nearshore coastal waters.

3 Methodology

3.1 Introduction

The methodology is divided into two broad sections:

1. [Section 3.2](#) summarises the remote sensing techniques developed as part of this research to address the primary research question; and
2. [Sections 3.3](#) and [3.4](#) describe the geochemical tracing techniques and concurrent nutrient analysis undertaken to address the second and third research questions, specifically to:
 - (i) Verify the presence of groundwater discharge at the potential sites identified through thermal image analysis; and
 - (ii) Provide a qualitative and quantitative evaluation of groundwater discharge and associated nutrient input at two case-study

locations, Hook Head, Co. Wexford, and Kinvarra, Co. Galway.

While the successful application of the methodology to freshwater systems was revealed through a case study of Lough Mask, the results are not presented here but are available in the End of Project Report.

The study area comprised the island of Ireland ([Fig. 3.1](#)), demarcated by the intercept of six Landsat ETM+ scenes from Path 206 Row 024 through Path 208 Row 024 of the WRS-2 (Landsat ETM+ Worldwide Reference System (WRS)) co-ordinate system. The area spans the coastline from Mayo in the north-west (54.30° N, 10.00° W), extending south-east to Wexford (52.34° N, 6.44° W). Two locations, Hook Head, Co. Wexford, and Kinvarra, Co. Galway, were chosen as specific case-study sites following the results of the thermal image analysis which revealed both locations as potential SGD sites.

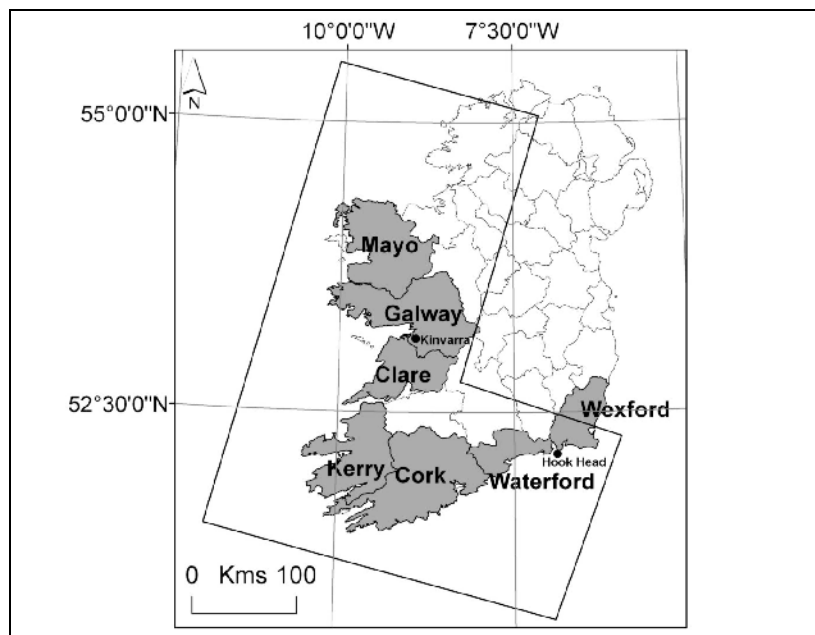

Figure 3.1. Location map of the study area, the island of Ireland, illustrating Landsat ETM+ coverage areas by county. The bold outline demarcates the combined geographical extent of the Landsat ETM+ scenes acquired from the United States Geological Survey and the Global Land Cover Facility between Paths 206 Row 024 through Path 208 Row 024 of the Landsat World Reference System and used in the analysis. The location of case-study sites, Hook Head, Co. Wexford, and Kinvarra, Co. Galway, are also included.

3.2 Remote Sensing Techniques for SGD Detection and Analysis

To develop a methodology that would facilitate a regional-scale assessment of groundwater discharge from coastal aquifers, the optimal time period for SGD detection via remote sensing techniques must firstly be established. A comparison of SST acquired from the Marine Institute (MI) Ireland and groundwater temperature data from a selection of boreholes sampled by the EPA Ireland in 2008 revealed that maximum temperature differences occur through the summer months (Fig. 3.2). Consequently, this study was based on the fact that inflow of cooler groundwater into warmer nearshore waters results in buoyant plumes of low salinity water and lower temperatures at the sea surface in the zones of groundwater discharge.

A total of 26 publicly available Landsat ETM+ TIR images of Ireland, spanning the time period between May 2001 and June 2010, were acquired from a variety of sources including the European Space Agency (ESA), the US Geological Survey (USGS) and the Global Land Cover Facility (GLCF) at the University of Maryland, USA. The images obtained were mostly cloud free with a scene-centre flyover time of between 11:15 h and 11:30 h GMT (local time). Land pixels in each scene were masked based on a threshold of Landsat ETM+ Band 5 image values from a clear,

cloud-free day. The available archived images envelop almost the entire coastline of Ireland and a subset of six images (Table 3.1) was used to create temperature anomaly maps of coastal waters for use in a regional-scale assessment of SGD. A full and detailed description of the methodology is available within Wilson and Rocha (2012).

3.2.1 Integrating ancillary spatial data sets within a GIS to characterise potential SGD sites

To gauge the potential for groundwater discharge at the sites identified and help direct subsequent in-situ verification in addition to use of the standardised maps, spatial data sets describing onshore bedrock geology and characterising aquifer groundwater body type were acquired from the GSI. Using this information, combined with the results from the thermal mapping within a GIS, the locations identified around the coastline can be further characterised and ranked in their importance as potential groundwater sources.

3.3 Geochemical Tracing I: A Case Study of Hook Head, Co. Wexford

Geochemical tracing techniques were employed to groundtruth the seasonal anomalies observed off Hook Head to verify the presence of SGD, while providing both a qualitative assessment and quantitative estimate of fresh groundwater inputs to the coastal

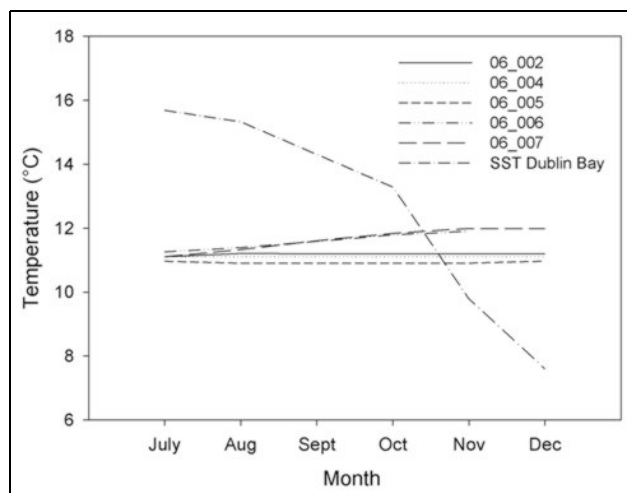

Figure 3.2. Comparison of groundwater temperature values recorded from the Bog of Ring boreholes located in Dublin (identified through unique codes and sourced from the EPA) and sea surface temperature measurements recorded across Dublin Bay by the Celtic Voyager (sourced from the Marine Institute) in 2008.

Table 3.1. Sample of six Landsat ETM+ TIR images acquired for Ireland, detailing time of satellite overpass and atmospheric correction parameters (upwelling and downwelling radiances, atmospheric transmission) derived from an online atmospheric correction parameter tool (<http://atmcorr.gsfc.nasa.gov/>) used to derive scene-at-surface kinetic temperature values (SST).

Scene acquisition date (yy/mm/dd – hh:mm GMT)	Location (county)	Upwelling (W/m ² /sr/μm)	Downwelling (W/m ² /sr/μm)	Transmission (%)
1999/08/21 – 11:17	Mayo	No data available for imagery pre-2000		
2000/07/22 – 11:26	Mayo/Galway	2.03	3.24	0.73
2007/06/08 – 11:25	Galway/Clare	1.50	2.42	0.79
2004/05/23 – 11:18	Kerry/Cork	0.99	1.65	0.85
2004/06/15 – 11:24	Cork	1.52	2.43	0.80
2010/06/02 – 11:15	Waterford/Wexford	1.25	2.05	0.82

zone. A series of coastal surveys was conducted in 2010 and 2011 to map the spatial distribution of radon and salinity within the nearshore waters of the Hook coastline to confirm the presence of SGD and to identify any radon hot spots or SGD sources at specific points along the shoreline. Concurrent nutrient sampling was also undertaken to determine the contribution of the coastal aquifer to the nutrient load within nearshore waters. Using the radon and salinity data obtained from the surveys, mixing lines were constructed to determine potential sources of freshwater to the waters off Hook and to provide a qualitative assessment of land–sea fluxes. Finally, a mass balance approach was employed to provide a quantitative estimate of SGD discharge rates and associated nutrient loading to the coastal waters off Hook.

During the first survey (5 August 2010) several sweeps of the coastline were completed with increasing distance from shore to ensure that the specific areas off Hook where thermal anomalies were observed during thermal image analysis were accounted for (Fig. 3.3). During the second survey (11 August 2010), radon activities were monitored in close proximity to the shoreline to determine specific radon ‘hot spots’ or exit points of SGD. In 2011, the surveys were repeated although during the final survey, 22 July 2011, radon activities upstream of the estuary were recorded.

A boat speed of 4 knots was maintained during the surveys whilst sailing parallel to the coastline. The boat’s position was continuously recorded using a

Garmin GPS and water depths were recorded on-board using a digital hand-held sonar system (Hawkeye). A conductivity, temperature, depth (CTD) probe (Schlumberger Water Services) was positioned above the pumps beneath the water to continuously record conductivity and temperature from which continuous measurements of salinity were then derived. Water samples were gathered on-board for nutrient analysis and concentrations of nitrite (NO₂⁻), ammonia (NH₃), nitrate (NO₃⁻) and silicon (Si) were quantified in the laboratory using a flow injection analyser (FIA) as outlined in Grasshoff et al. (1999). Phosphorus concentrations were measured using spectrophotometry.

Finally, water and sediment samples were gathered from a variety of locations around Hook, including two coastal springs and a surface water discharge site at Ballystraw (Duncannon) to determine background and endmember radon, salinity and nutrient values. Using background radon and salinity values from coastal springs, theoretical mixing lines were constructed around which the values from the surveys were plotted to help determine potential sources (inputs) of fresh water observed off Hook. A mass balance approach (Fig. 3.4) was adopted to obtain a quantitative measurement of the different types of radon fluxes, including all sources and sinks of radon into the coastal zone, from which to determine the rate of SGD (i.e. the rate of advection of pore water from the shoreline to nearshore coastal waters). The methodology followed as part of this research is similar to that outlined by Burnett and Dulaiova (2003).

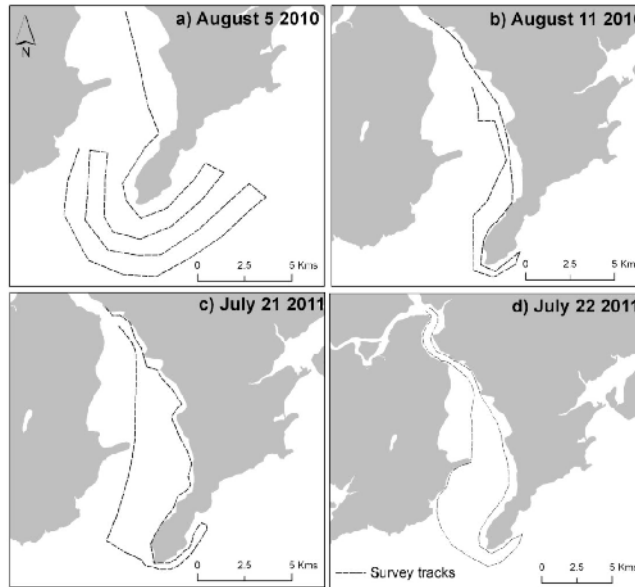

Figure 3.3. Hook Head, Co. Wexford, location of a pilot study for continuous monitoring of ^{222}Rn to verify the presence of SGD detailing survey tracks completed on (a) 5 August 2010, (b) 11 August 2010, (c) 21 July 2011, and (d) 22 July 2011.

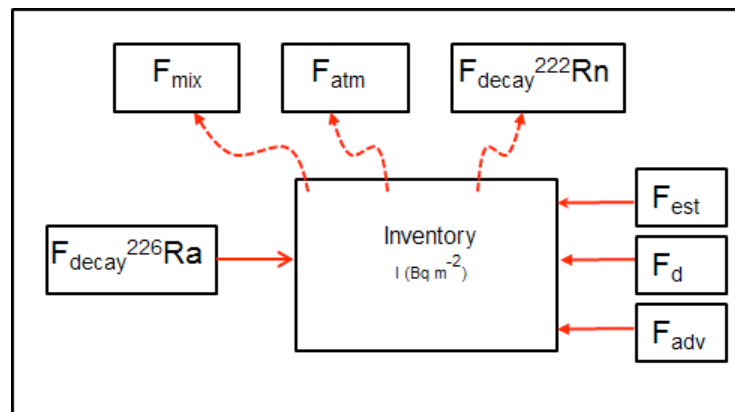

Figure 3.4. Conceptual model of the radon mass balance approach with the use of continuous radon measurements for estimating submarine groundwater discharge (SGD). I (Inventory) refers to the total amount of excess radon per measurement location; F_{atm} refers to the loss of radon via degassing to the atmosphere; $F_{\text{decay}}^{222}\text{Rn}$ refers to the loss of radon through decay; F_{mix} refers to the loss of radon due to mixing with offshore waters; $F_{\text{decay}}^{226}\text{Ra}$ refers to the input of radon from the decay of its parent ^{226}Ra ; F_{est} is the input of radon from the estuary; F_{d} is the diffusion of radon from sediments and F_{adv} is the advective flux of radon through the seabed or SGD.

The mass balance approach assumes a steady-state condition, i.e. the inventory does not change over time and the sources of radon into the system are balanced by the sinks (Eqn 3.1).

$$F_{\text{adv}} + F_{\text{d}} + F_{\text{est}} + F_{\text{decay}}^{226}\text{Ra} = F_{\text{decay}}^{222}\text{Rn} + F_{\text{atm}} + F_{\text{mix}}$$

Eqn 3.1

where F_{adv} is the advective flux of radon through the seabed or SGD, F_{d} is the diffusion of radon from sediments, F_{est} is the input of radon from the estuary, $F_{\text{decay}}^{226}\text{Ra}$ refers to the input of radon from the decay of its parent ^{226}Ra , $F_{\text{decay}}^{222}\text{Rn}$ refers to the loss of radon through decay, F_{atm} refers to the loss of radon

via degassing to the atmosphere, and F_{mix} refers to the loss of radon due to mixing with offshore waters. Assuming a steady-state condition, the excess radon remaining in the system after all known sources and sinks have been calculated is accounted for by the remaining unknown term F_{adv} ($Bq/m^2/day$) or the advective flux (Eqn 3.2).

$$F_{adv} = F_{decay}^{222Rn} + F_{atm} - F_d - F_{est} - F_{decay}^{226Ra} + F_{mix} \quad \text{Eqn 3.2}$$

The flux of radon degassing to the atmosphere (F_{atm}) from an open water body is governed by diffusion due to the radon concentration gradient at the air/water interface and by turbulent transfer at the water surface and is determined from Eqn 3.3:

$$F_{atm} = v (C_W Rn - K C_{air} Rn) \quad \text{Eqn 3.3}$$

where $C_W Rn$ and $C_{air} Rn$ are the radon concentrations in water and atmospheric air (Bq/m^3), respectively, K is the dimensionless partition coefficient determined from the Fritz–Weigel equation (Eqn 3.6), and v (cm/h) is the radon transfer velocity, which is governed by wind speed and water currents and is determined as follows (Schmidt and Schubert, 2007) (Eqn 3.4):

$$v_{600} = 0.45 (U_{10})^{1.6} \frac{(ScRn)^{-2/3 \text{ or } -1/2}}{600} \quad \text{Eqn 3.4}$$

The term 600 represents a standardisation, U_{10} represents the wind speed 10 m above the water surface (m/s), $ScRn$ represents the dimensionless ‘Schmidt number’ of radon (the ratio of the kinematic viscosity of water and the radon molecular diffusion coefficient in water derived from Liss and Merlivat (1986) to the power of $-2/3$ or $-1/2$ where wind speeds are less than or greater than 3 m/s , respectively).

Rates of radon decay (F_{decay}^{222Rn}) and radium decay (F_{decay}^{226Ra}) are calculated to sum the loss of radon through the decay of ^{222}Rn and influx of radon through the decay of ^{226}Ra to the radon inventory. The rate of decay is measured using area-weighted average inventories for radium ($I^{226}Ra$) and radon ($I^{222}Rn$) and applying a daily decay rate coefficient (λRn) to the inventories (Eqns 3.5 and 3.6):

$$F_{decay}^{222Rn} = \lambda Rn \times I^{222}Rn \quad \text{Eqn 3.5}$$

$$F_{decay}^{226Ra} = \lambda Rn \times I^{226}Ra \quad \text{Eqn 3.6}$$

^{226}Ra activities were obtained from Schmidt et al., (1998) and the radon activities were measured from the continuous survey. Area-weighted average radium and radon inventory values were generated from the sample points using an ArcGIS spatial interpolation algorithm.

To convert the radon flux estimates based on the mass balance to an input of groundwater into the system as a volume per unit time, firstly, the advective flux estimate ($Bq/m^2/day$) was multiplied by the area (m^2) across which the survey was undertaken. An estimate for the ^{222}Rn concentration of the advecting fluids must also be determined. Endmember concentration of radon can be determined either through sampling from the source aquifer via a coastal spring or via sediment diffusion experiments. As radon is highly variable in groundwater, radon activity was measured in this study from two coastal springs and one inland spring to determine an average freshwater endmember radon concentration for the aquifer. Finally, the radon flux estimate (Bq/day) is divided by the excess radon concentration in the source aquifer ($Ex^{222}Rn_{gw}$) (Bq/m^3) to produce a discharge volume (Q) of groundwater per day (m^3/day) (Eqn 3.7):

$$Q = \frac{F_{adv} \times \text{survey area}}{Ex^{222}Rn_{gw}} \quad \text{Eqn 3.7}$$

3.4 Geochemical Tracing II: A Case Study of Kinvarra Bay, Co. Galway

An intense field campaign was conducted during July 2010 to investigate the effect of tidal variability on the rate and levels of SGD and associated nutrients into Kinvarra Bay, Co. Galway. Kinvarra was selected as a study area as it is located in a highly karstified limestone region, well known for the occurrence of SGD due the high transmissivity of the bedrock geology (Drew, 2001). Despite knowledge that groundwater seepage is occurring, neither estimates of the amount of groundwater seepage nor the associated nutrient loading into Kinvarra Bay via SGD have been established to date.

Continuous radon monitoring and concurrent nutrient sampling were undertaken to determine both qualitatively and quantitatively the effect of tidal

variability on the rate and levels of SGD. A comprehensive assessment of SGD inputs was completed following two in-situ 24-h radon monitoring campaigns encompassing two complete tidal cycles, at two locations in Kinvarra, namely Dunguaire Castle (53°8' N, 8°55' W) and Parkmore Pier (53°10' N, 8°58' W) (Fig. 3.5). To fulfil the objectives of the mass balance approach to calculating estimates for SGD, additional grab samples of radon were gathered from one well (Patrick's Well) and a borehole (Loughcurragh South) in the area and at several locations within the Bay at low and high tide (Fig. 3.6). Background levels of atmospheric radon were estimated following a 24-h sniff sample, and sediment was gathered and processed to determine the background levels of radon diffusion from the soil. Concurrently, water samples were gathered for nutrient analyses (nitrite, nitrate and silicon) to determine the anthropogenic component of SGD. A second field campaign was undertaken in June 2011 to verify the results from the first field study at Kinvarra. A third and final field campaign was undertaken in September 2011 to determine water residence times in the Bay using the delayed radium coincidence counter system (RaDeCC).

Because radon sampling for the purpose of constructing a mass balance of groundwater inputs to Kinvarra is undertaken at a fixed point rather than through a continuous (moving) survey of the Bay, the mass balance approach adopted is somewhat different to that used for Hook. Regarding Kinvarra, the authors were particularly interested in the role of the tide in the variability of the discharge of groundwater and associated substances into the Bay. The mass balance was constructed from the in-situ sampling undertaken at Parkmore Pier.

In addition, a further objective of the study was to determine the utility of the short-lived isotopes of radium (^{223}Ra and ^{224}Ra) as tracers of water residence time in Kinvarra Bay using a method pioneered by Moore (2000). A series of moored buoys (12 in total) with attached manganese (Mn) fibres were deployed for 24 h (four tidal cycles) at several stations across Kinvarra Bay on 8 September 2011 to obtain a spatial representation of radium activity integrated over both high and low tides (Fig. 3.7). After deployment, ^{224}Ra and ^{223}Ra activities were measured using RaDeCC techniques (Moore and Arnold, 1996) and the ratio of the two activities was used to estimate 'radium ages' of the water in the Bay as per Moore

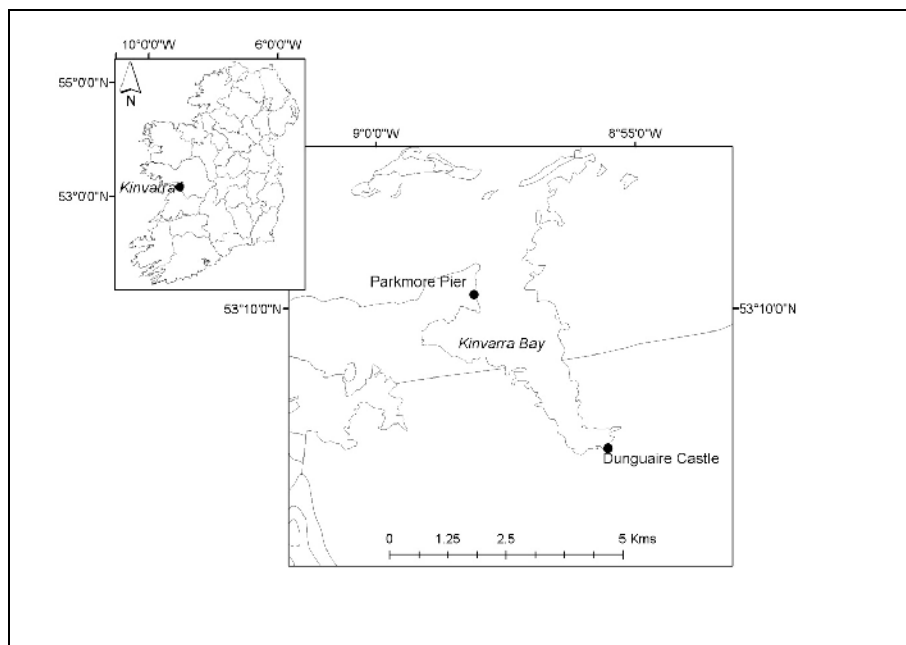

Figure 3.5. Map of the study area (Kinvarra Bay, Co. Galway), detailing locations of radon monitoring stations, Dunguaire Castle (53°8' N, 8°55' W) and Parkmore Pier (53°10' N, 8°58' W).

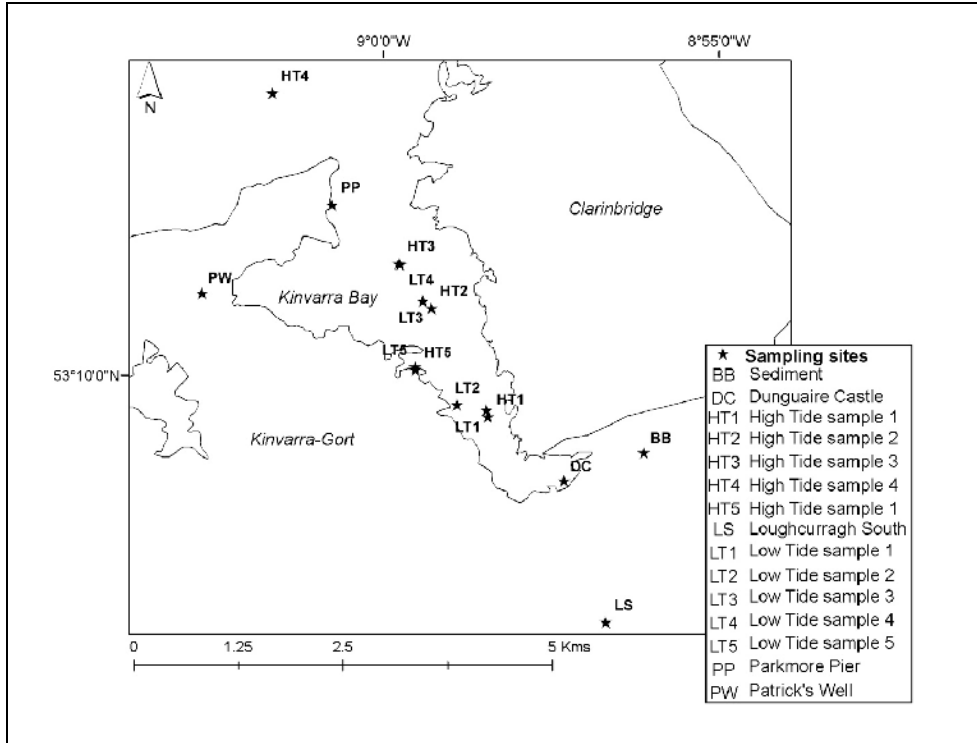

Figure 3.6. Map of study area (Kinvarra Bay, Co. Galway), illustrating sample site locations and spatial extent of the groundwater bodies (Kinvarra–Gort and Clarinbridge) bordering the inlet.

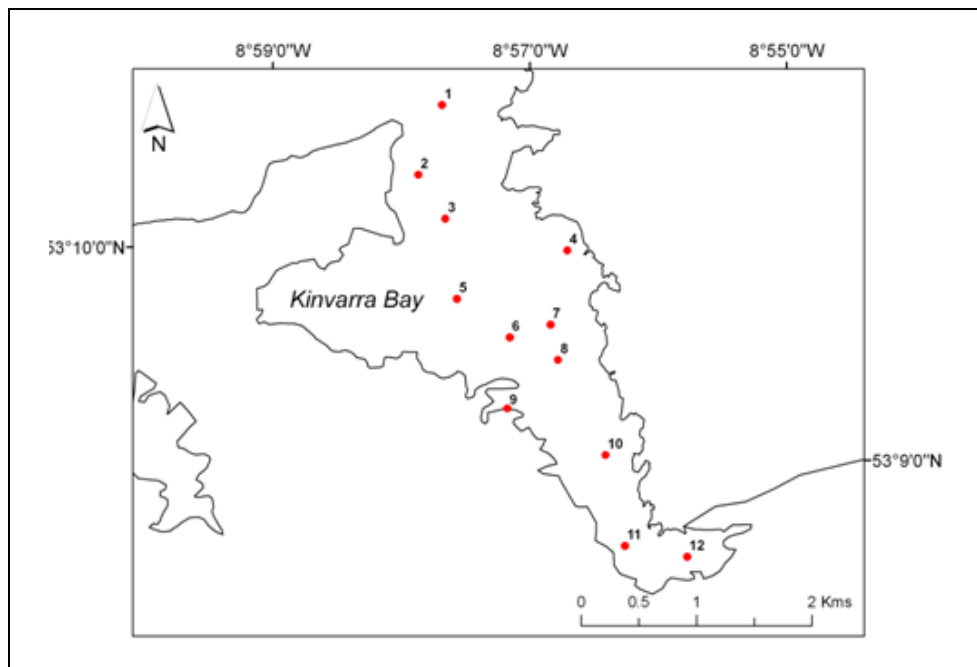

Figure 3.7. Map of Kinvarra Bay showing locations of radium sampling stations. The position of each buoy is represented with a red dot.

(2000) and Houghman and Moran (2007). This approach assumes that there is a constant single major source of radium into the Bay and that losses of radium are due only to dilution and radioactive decay. The method also assumes that background concentrations of radium within the Bay are negligible.

The apparent radium age is an age of the water mass that is derived based on the $^{224}\text{Ra}/^{223}\text{Ra}$ activity ratio which is the result of radioactive decay and mixing of water masses, i.e. groundwater input and low radium bay water. Apparent age derived using this equation reflects an integrated history of the circulation over the past several days (residence time of the water).

4 Results and Discussion

4.1 Thermal Image Analysis

The results from the thermal image analysis (SST, temperature anomaly (TA) and standardised temperature anomaly (STA) values derived from Landsat ETM+ TIR data of Irish coastal waters) clearly revealed the presence of large buoyant plumes of cold water at numerous locations around the Irish coastline, demonstrating the success of the developed methodology where over 30 potential SGD sites were identified (Figs 4.1 and 4.2) using a time series of Landsat ETM+ TIR imagery acquired from publicly available online archives. When combined with additional ancillary spatial data sets sourced from the GSI, the onshore locations adjacent to potential SGD sites, from which the nearshore cold water plumes appear to originate, lend support to the observation that adjacent geological features on land may be acting as possible sources (Table 4.1). The onshore location of these potential sites is characterised by a

faulted, fractured and permeable bedrock geology, comprising predominantly limestone, mudstone or sandstone associated with locally important (productive) aquifer types (DoELG/EPA/GSI, 1999) highly conducive to the transmission of water.

Given these results, it is possible to indicate that the geologic structures onshore, such as karst, bedrock fissures and faults adjacent to the thermal plumes, may be serving as a hydrological pathway transporting potentially large volumes of groundwater and associated materials to the sea. The SST maps show that the pattern of large cold water plumes corresponds almost exclusively to the presence of aquifer fault lines that intersect the shoreline. The standardised temperature anomaly maps facilitate inter-scene comparison of the thermal signatures observed within nearshore waters (Fig. 4.3). In particular they illustrate that some of the largest negative temperature anomalies were recorded at

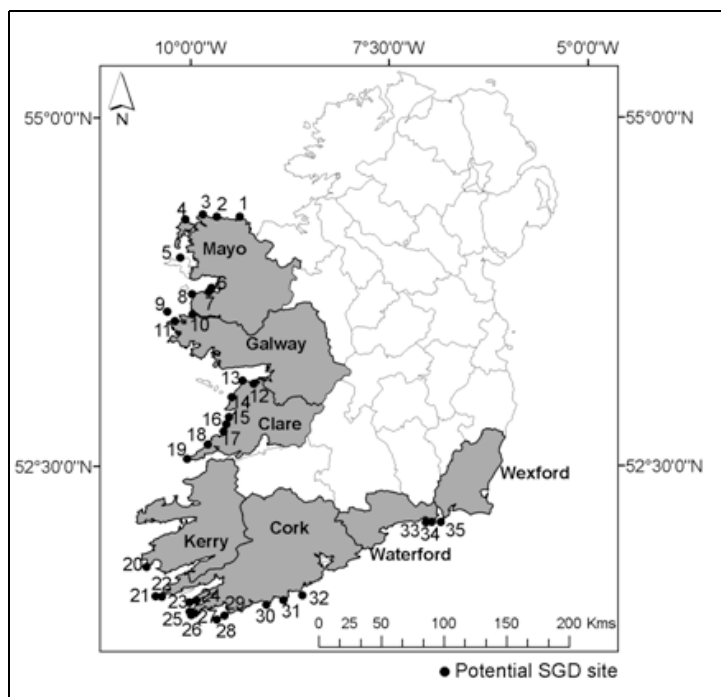

Figure 4.1. Locations of 35 potential sites of SGD based on visual inspection of SST maps derived from available Landsat ETM+ TIR images of Ireland acquired during summer months, May–August, from 1999 to 2010.

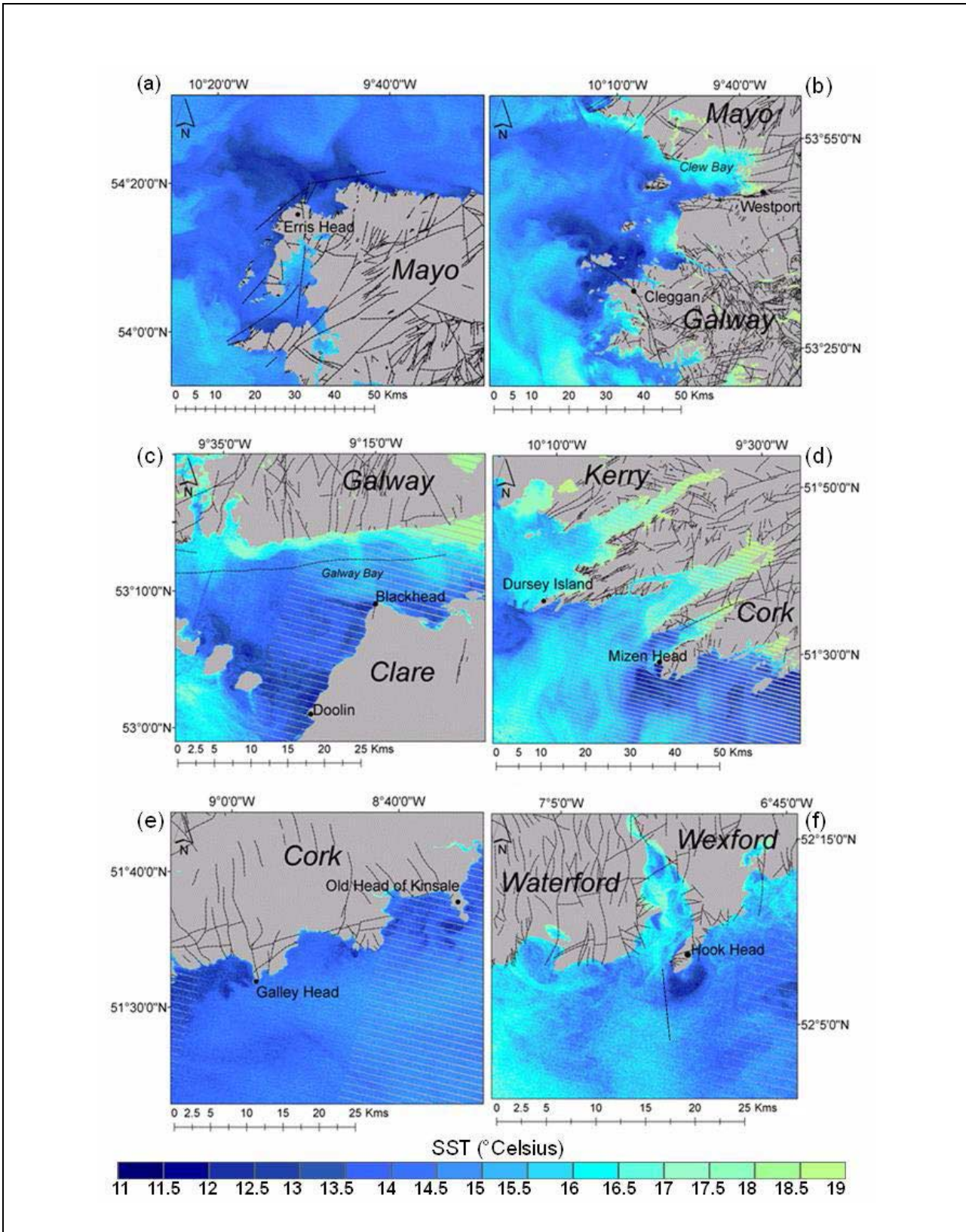

Figure 4.2. Series of SST maps ($^{\circ}\text{C}$) derived from Landsat ETM+ TIR imagery, acquired on (a) 21 August 1999, (b) 22 July 2000, (c) 8 June 2007, (d) 15 June 2004, (e) 23 May 2004, and (f) 2 June 2010, illustrating buoyant cold water plumes emanating from nearshore coastal waters and revealing potential sites for SGD off the Irish coastline. Dashed lines represent bedrock fault lines sourced from the GSI.

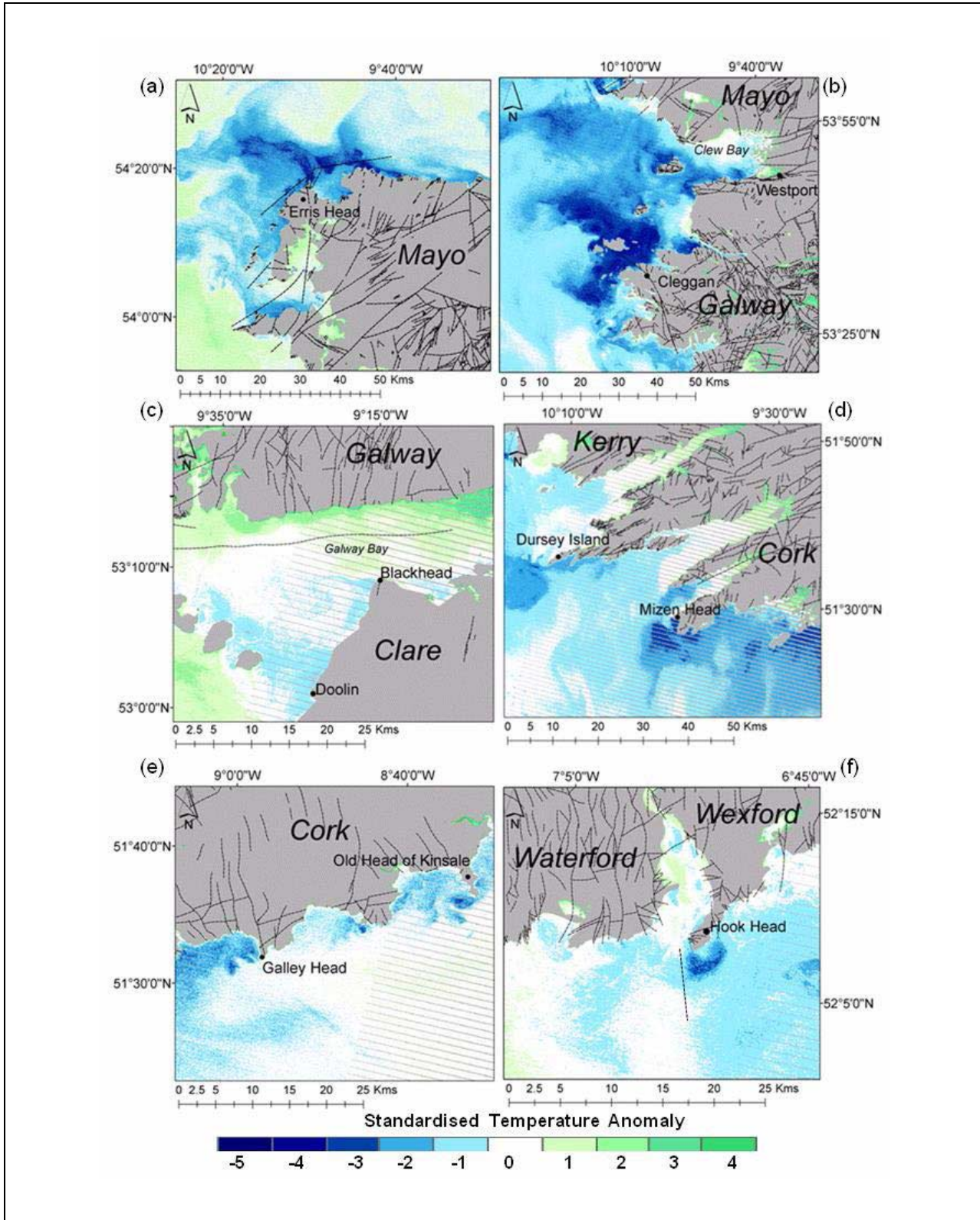

Figure 4.3. Series of STA maps (unitless) derived from Landsat ETM+ TIR imagery, acquired (a) 21 August 1999, (b) 22 July 2000, (c) 8 June 2007, (d) 15 June 2004, (e) 23 May 2004, and (f) 2 June 2010, facilitating inter-scene comparison of observed temperature anomaly. Large negative anomalies displayed in dark blue tones reveal the location of cold water plumes and the relative significance of the anomalies observed at different locations. Areas exhibiting higher than scene-average SSTs are displayed through green tones.

Table 4.1. Onshore locations of nearshore cold water anomalies and potential sites of SGD detected from SST and TA maps retrieved from available Landsat ETM+ TIR data of Ireland, including bedrock geology and aquifer type sourced from the GSI (DoELG/EPA/GSI, 1999).

Code	Site	County	Geology	Aquifer type		
1	Downpatrick Head	Mayo	Limestone & shale	Locally important, karstified		
2	Glinsk		Psammites & schists	Poorly productive		
3	Benwee Head					
4	Erris Head					
5	Slievemore Achill					
6	Clew Bay				Limestone & shale	Regionally important, karstified
7	Cooltraw Strand				Sandstone & siltstone	Poor except for local zones
8	Roonah Point					
9	Inishboffin	Galway			Schist	Poor except for local zones
10	Culfin		Mudrock & siltstone			
11	Cleggan		Quartzite			
12	Ballyvaughan Bay	Clare	Limestone & dolomite	Regionally important, karstified		
13	Blackhead		Cherty limestone			
14	Doolin					
15	Freaghcastle				Sandstone, siltstone & mudstone	Locally important, moderately productive
16	Caherrush Point					
17	Carricknola					
18	Kilkee					
19	Loop Head	Sandstone				
20	Bolus	Kerry	Sandstone & siltstone	Locally important, moderately productive		
21	Dursey Island		Sandstone & siltstone	Locally important moderately productive		
22	Crows Head				Poor except for local zones	
23	Sheep's Head				Sandstone & mudstone	Locally important moderately productive
24	Dunmanus					
25	Three Castle Head					
26	Mizen Head					
27	Barley Cove					
28	Cape Clear					
29	Sherkin Island	Mudstone, siltstone, sandstone	Poor except for local zones			
30	Toe Head					
31	Galley Head					
32	Old Head of Kinsale			Locally important moderately productive		
33	Brownstown Head	Waterford	Red conglomerates, sandstone, mudstone	Locally important moderately productive		
34	Swines Head					
35	Hook Head	Wexford	Limestone & dolomites	Locally important, karstified		

locations where bedrock fault lines extend several kilometres offshore. Erris Head, Co. Mayo, Cleggan, Co. Galway, and Hook Head, Co. Wexford, ([Fig. 4.3a](#), [b](#) and [f](#), respectively) are particularly good examples of this and it is most likely that the analysis has identified large offshore submarine springs at these locations. It is clear that the results of the thermal analysis have highlighted a visual spatial correlation between the location of the thermal plumes and onshore bedrock geology, warranting further investigation. The ancillary data also served to direct intensive field campaigns that were conducted at two key sites initially (Hook Head, Co. Wexford, and Kinvarra, Co. Galway) to verify that observed cold buoyant plumes were occurring as a consequence of groundwater discharge and not some other coastal process.

The largest negative STA values were detected within plumes mapped off the coastline north of Erris Head, Co. Mayo, north-west of Cleggan, Co. Galway, off Mizen Head, Co. Cork, and off Hook Head, Co. Wexford. These plumes form within metres of the shoreline and extend from over 2 km (e.g. [Fig. 4.3d](#) and [f](#)) to distances greater than 20 km offshore (e.g. [Fig. 4.3a](#) and [b](#)). The onshore locations of each potential site were further characterised using ancillary geological data from the GSI ([Table 4.1](#)).

4.2 Geochemical Tracing I: A Case Study of Hook Head, Co. Wexford

Elevated radon activities recorded during the July–August 2010 and July 2011 surveys confirmed the presence of SGD ([Figs 4.4](#) and [4.5](#)). Local radon hot spots are clearly identifiable along the peninsula at several points, for example at Broomhill Point and south of Lumsdin Bay ([Fig. 4.4](#)). The geology at Broomhill comprises faulted sandstone and mudstone and the Hook is comprised entirely of limestone with numerous fault lines south of Lumsdin Bay (DoELG/EPA/GSI, 1999). The aquifer bedrock in the area has been characterised as locally important and karstified, therefore considered highly conducive to the transmission of water. It is not surprising that the range in radon activities is higher for the second survey in 2010 ([Fig. 4.4b](#)), which was specifically designed to capture potential hot spots of radon close to the shoreline indicating sources of SGD. The first survey

undertaken in August 2010 spanned a greater surface area than the second ([Fig. 4.4](#)), where radon activities were recorded at considerable distances offshore (>5 km), allowing more time for degassing and mixing to impact the measurements, which resulted in a lower range of radon activity. The results were similar for the July 2012 surveys where the first survey targeted nearshore waters to identify local sources and recorded higher radon activities in comparison with the second, which spanned Waterford Harbour and included waters several kilometres offshore of the Hook ([Fig. 4.5a](#) and [b](#)). The specific locations of elevated radon activities along the Hook observed during the 11 August 2010 and 21 July 2011 surveys are similar despite differences in tidal stage between surveys.

Concurrent salinity sampling was completed to distinguish between the possible sources of radon contributing to the activities observed within the nearshore waters off Hook and, more specifically, to evaluate whether these are the result of groundwater seepage at the coast. The negative correlation between radon and salinity indicates that waters with lower salinity have higher radon concentrations (than waters with higher salinity which reveal lower radon concentrations) due to an admixture of groundwater, and this addition of groundwater to the estuary is further explained by examining the distribution of radon against salinity around freshwater–seawater mixing lines. The plot of radon against salinity for each of the four surveys is presented in [Fig. 4.6](#). From [Fig. 4.6a](#) and [c](#), it is clear that the entire set of sample points plot above the estuarine mixing line during the 5 August 2010 and 21 July 2011 surveys, thus precluding the estuary as the primary source of the excess radon activities measured along the Hook. A small number of points plotted below the estuarine mixing line for the 11 August 2010 and 22 July 2011 surveys. The spatial distribution of these points, illustrated in [Fig 4.7](#), clearly shows their location within the upper reaches of the estuary. A number of survey points plotted above the groundwater–seawater mixing line indicating several hot spots of radon activity within relatively high salinity waters (>30 ppt) through each of the surveys. This demonstrates that the fresh water contributing to the radon activities observed at these sites is being added

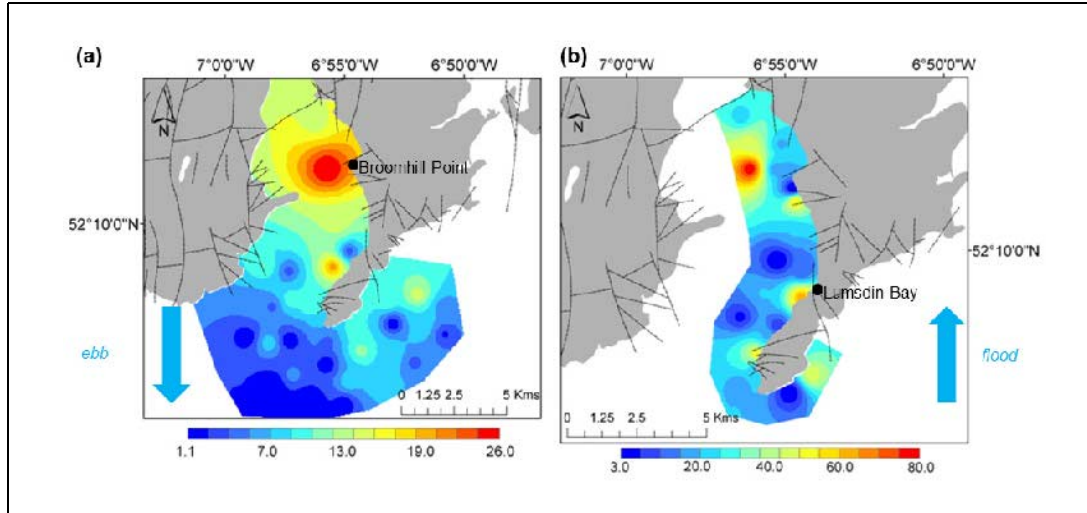

Figure 4.4. Excess radon activity levels for the coastal waters surrounding Hook recorded during surveys undertaken on (a) 5 August 2010 and (b) 11 August 2010. Higher radon activities are displayed in orange through red hues and lower radon activity values are displayed in navy through turquoise hues in Bq/m^3 . Blue arrows indicate tidal movement through the course of the survey.

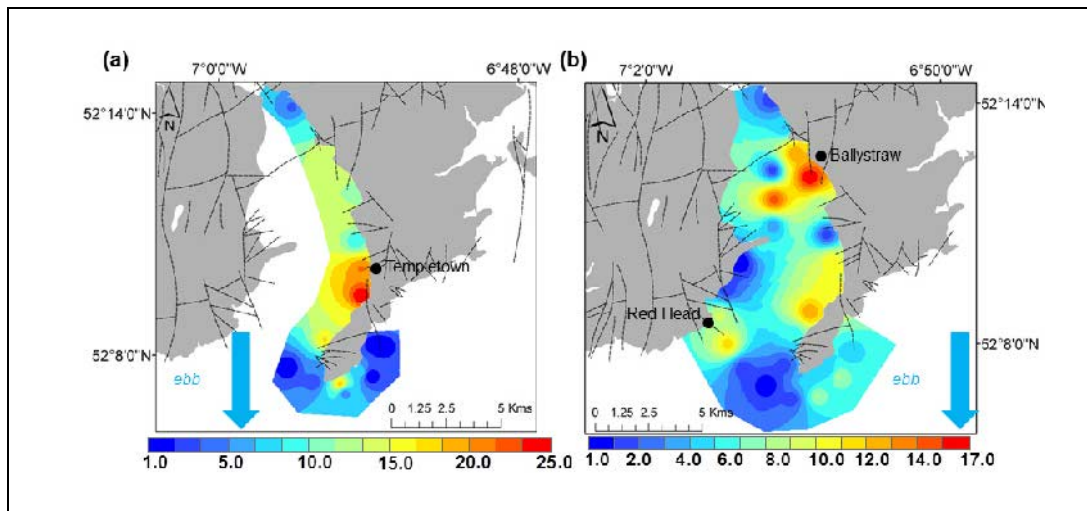

Figure 4.5. Excess radon activity levels for the coastal waters surrounding Hook recorded during surveys undertaken on (a) 21 July 2011 and (b) 22 July 2011. Higher radon activities are displayed in orange through red hues and lower radon activity values are displayed in navy through turquoise hues in Bq/m^3 . Blue arrows indicate tidal movement through the course of the survey.

to the system from a local source along the peninsula and is not coming from the estuary.

The results from the mass balance calculations (Table 4.2) reveal the decay of radon as the greatest loss term in all of the surveys with one exception – during the first survey from the 2011 campaign atmospheric losses and loss from the decay of radon

were almost identical at $\sim 8 \text{ Bq/m}^2/\text{day}$. When the mass balances were solved to determine the advective fluxes of radon (i.e. the unknown term in the mass balance), the largest values were determined from the 11 August 2010 survey, during which the highest radon activity levels were recorded (Table 4.2). Groundwater discharge rates (m/day) are determined by dividing the advective or SGD flux ($\text{Bq/m}^2/\text{day}$) by the endmember

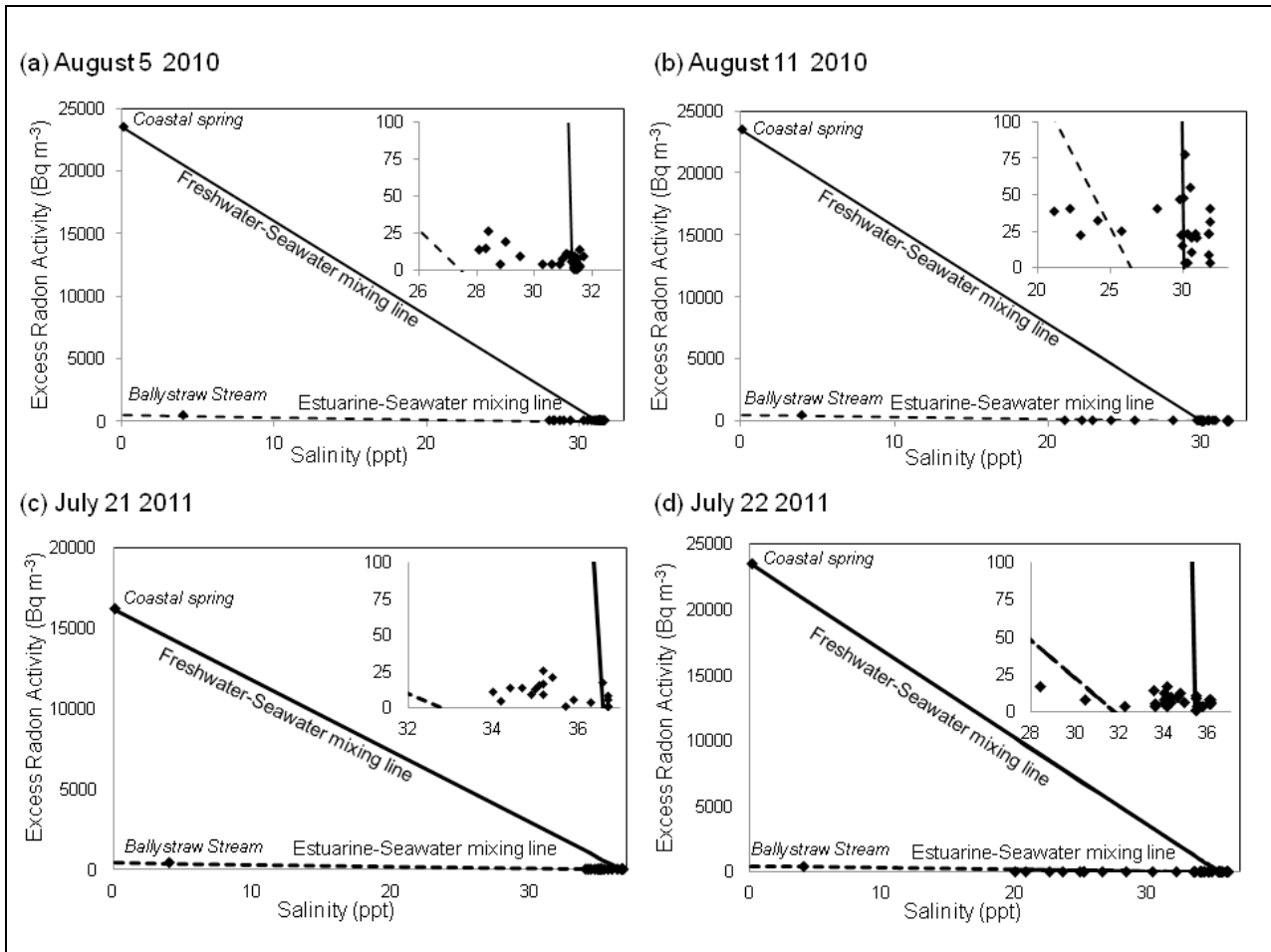

Figure 4.6. The plot of salinity versus excess radon activity including freshwater–seawater and estuarine–seawater mixing lines for the 2010 (5 and 11 August) and 2011 (21 and 22 July) surveys. Inserted graphs reveal the distribution of sample points above the estuarine–freshwater mixing lines indicating the addition of radon from local sources along the Hook.

radon activity level (Bq/m³). Groundwater endmember activity levels were sampled from a coastal spring and the results showed that radon activity levels were lower in July 2011 compared with those in August 2010. The same trend was visible from the continuous surveys, where, on average, radon concentrations were higher in coastal waters off Hook during 2010 relative to 2011.

To account for the impact that differences in the areal extent of each survey had on the resultant groundwater discharge rates as determined by mass balance, volumetric discharge rates were calculated for comparison by multiplying the groundwater discharge rate (m/day) by the spatial extent of each survey (m²). The results show that the first survey spanned the largest area and yielded the greatest

volumetric groundwater discharge rate. The results also reveal that, while the second survey undertaken in 2010 spanned a slightly smaller area than the first survey in July 2011, the volumetric discharge rates were more than twice as high on 11 August 2010 than on 21 July 2011. The surveys in July 2011 were recorded on consecutive days and the groundwater discharge rates are very similar, between 3.09×10^{-4} m/day and 3.6×10^{-4} m/day. The difference between the volumetric discharge rates for the July 2011 surveys (1.29×10^4 m³/day and 2.43×10^4 m³/day for 21 and 22 July, respectively) simply reflects the differences in survey area size between the dates, where the second survey spanned over double the areal extent of the first. The general trend observed from the surveys is that, on average, radon activity

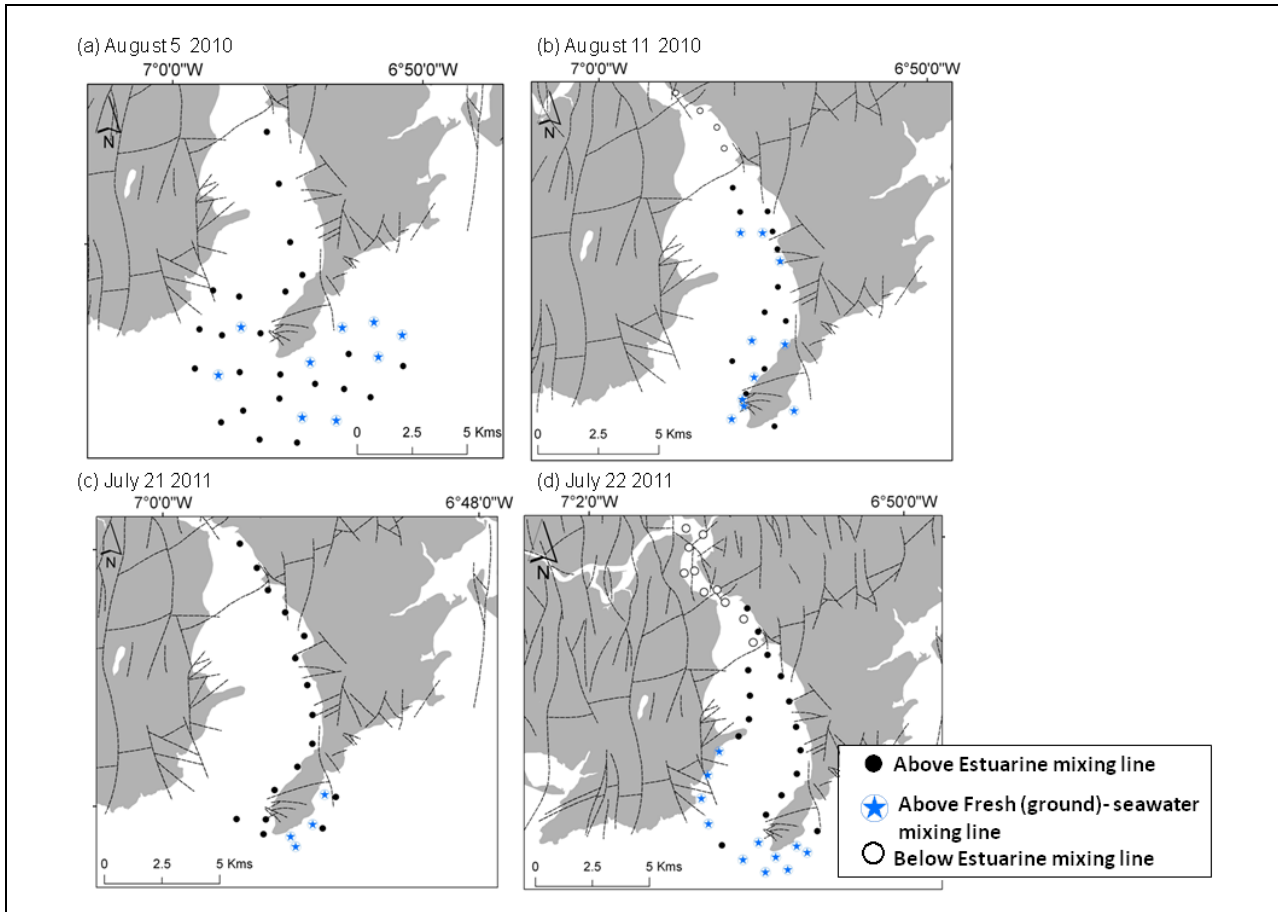

Figure 4.7. Spatial distribution of sample points as plotted around freshwater–seawater and estuarine–seawater mixing lines for the 2010 ((a) 5 August and (b) 11 August) and 2011 ((c) 21 July and (d) 22 July) surveys. Survey points plotting above and below the estuarine–seawater mixing line are highlighted in black and white, respectively. Points plotting above the freshwater–seawater mixing line are depicted with blue stars and represent the addition of radon to the system.

levels were higher for the 2010 surveys than for the 2011 surveys, which translated to higher groundwater discharge rates as determined by mass balance calculations on 5 and 11 August 2010 compared with July 2011.

Overall, the groundwater discharge rates into the area surveyed for each year are reasonably close in value and within the limits of values reported elsewhere. Groundwater fluxes into the surveyed areas varied between 0.03 cm/day and 0.13 cm/day. The greatest fluxes were recorded during the first two surveys in August 2010 and the maximum excess radon activity was recorded during the second survey (80 Bq/m³), producing a flux rate (0.13 cm/day) almost twice that of the first (0.07 cm/day). By comparison, rates between 2 and 10 cm/day were measured in the Gulf of Mexico

(Cable et al., 1996) and between 0.06 and 1.9 cm/day in Sao Paulo (Oliveira et al., 2006). It is important to note that the amount of radon present in seawater depends on a number of factors, including the rates of seawater pumping, radon activity levels within discharging groundwater, the production rates of sea-floor sediments, water depth and offshore mixing, all of which may change and vary through time associated with other factors such as meteorological conditions (precipitation, wind speeds) and tidal stage.

In addition to detecting where SGD is occurring around the Irish coastline and providing qualitative assessments and quantitative estimates of groundwater discharge rates, the final objective of the fellowship was to contribute to an increased knowledge of the links between groundwater

Table 4.2. Results from the radon mass balance approach to quantify the amount of submarine groundwater discharging into the coastal waters off Hook generated following four surveys undertaken in 2010 (5 and 11 August) and 2011 (21 and 22 July). Computed losses of radon from the system include atmospheric degassing (F atmosphere) and the decay of radon (F decay ^{222}Rn) and calculated source contributions of radon include diffusion from sediment (F sediment), decay of radon parent isotope ^{226}Ra present in the ocean (F decay ^{226}Ra) and the advective component, submarine groundwater discharge (F SGD).

Survey date	Losses (sinks)		Gains (sources)			Groundwater endmember radon activity (Bq/m ³)	Groundwater discharge (m/day)	Study area (m ²)	Volumetric discharge (m ³ /day)
	F atmosphere	F decay ^{222}Rn	F sediment	F decay ^{226}Ra	F SGD				
	(Bq/m ² /day)	(Bq/m ² /day)	(Bq/m ² /day)	(Bq/m ² /day)	(Bq/m ² /day)				
5 August 2010	6.22	20.634		3.426	16.19	23,517	6.88×10^{-4}	1.13×10^8	7.81×10^4
11 August 2010	13.87	24.77	7.24	1.308	30.09	23,517	1.28×10^{-3}	3.10×10^7	3.97×10^4
21 July 2011	8.68	8.127		1.093	8.47	16,167	3.6×10^{-4}	3.58×10^7	1.29×10^4
22 July 2011	3.65	13.237		2.378	7.27	16,167	3.09×10^{-4}	7.85×10^7	2.43×10^4

discharge and contaminant inputs to determine whether SGD should be considered a potential coastal pressure source when implementing water and land resource management policies in line with the WFD. Concurrent nutrient analyses undertaken during the continuous surveys of Hook in August 2010 revealed no statistically significant correlation with radon activities and the levels of nutrients measured in nearshore coastal waters off Hook during the sampling period (Table 4.3) were within accepted EPA water quality thresholds (Lucey, 2006). A number of factors such as uptake or storage of nutrients by macrophyte biomass (Valiela et al., 1990) and mixing with seawater may result in the dilution of nutrients to low/below detection measurement levels. However, data from Wexford County Council reveal that nitrate levels in wells across the Fethard aquifer breach the 50-mg/l threshold for drinking water quality in a number of instances (Table 4.4) and the potential coastal ecosystem impact of nitrate-rich groundwater discharging into the coastal waters around Hook must be considered.

Table 4.3. Ranges in nutrient values recorded 5 and 11 August 2010 in 20-min intervals throughout the coastal survey.

Nutrient	Concentration range 5 August 2010 (mg/l)	Concentration range 11 August 2010 (mg/l)
Nitrate	0–0.298	0–0.589
Silica	0–0.20	0–0.475
Ammonia	0–0.015	0–0.044
Phosphorus	0–0.01	0–0.02

Table 4.4. Nutrient results for groundwater samples from wells within the Fethard aquifer, including 224 private wells.

Nutrient	Concentration range (mg/l)
Nitrate	1–92
Silica	0.026–3.426
Ammonia	0.003–0.056
Phosphorus	0.0018–0.012

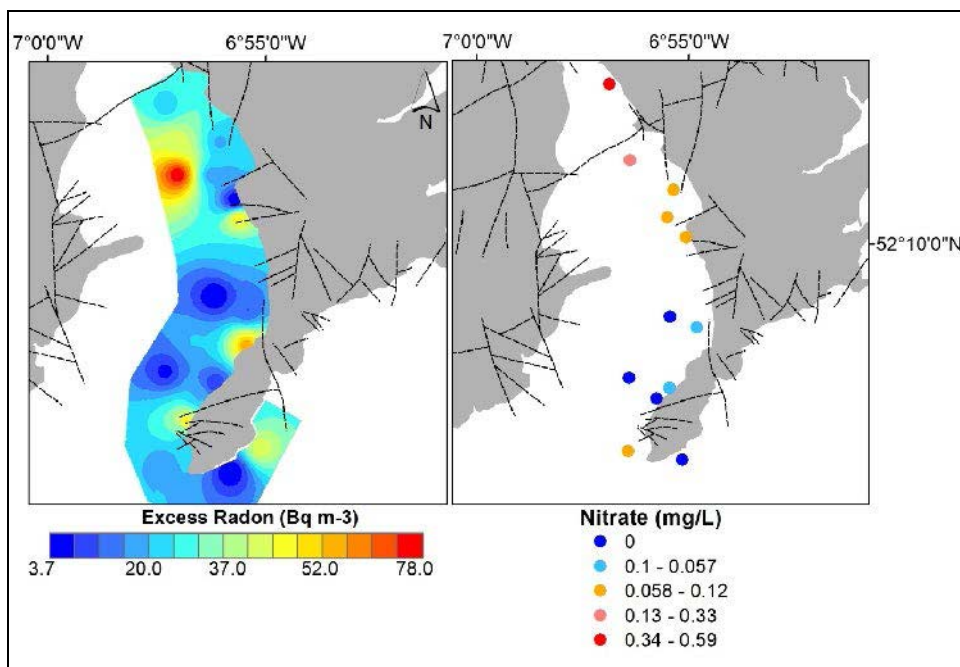

Figure 4.8. A comparison of radon activity (Bq/m³) and nitrate concentrations (mg/l) recorded during the 11 August 2010 survey. Higher radon values are displayed in yellow through orange to red hues, lower values are displayed in navy through dark blue to green tones. Higher phosphate concentrations are in red to pink through orange tones, low phosphate concentrations in blue tones.

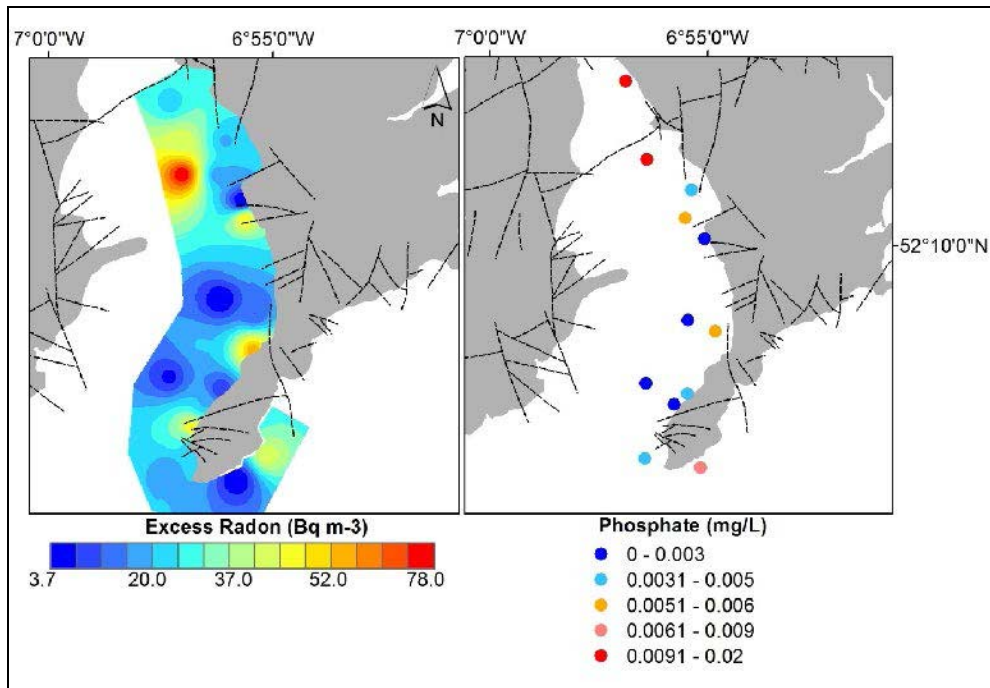

Figure 4.9. A comparison of radon activity (Bq/m^3) and phosphate concentrations (mg/l) recorded during the 11 August 2010 survey. Higher radon values are displayed in yellow through orange to red hues, lower values are displayed in navy through dark blue to green tones. Higher phosphate concentrations are in red to pink through orange tones, low phosphate concentrations in blue tones.

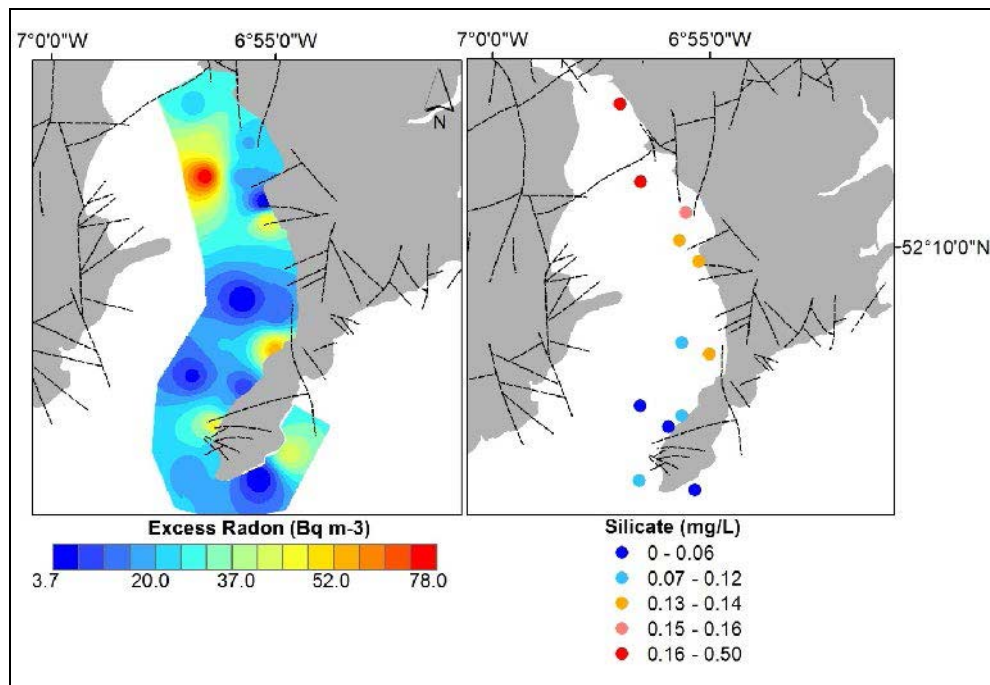

Figure 4.10. A comparison of radon activity (Bq/m^3) and silicate concentrations (mg/l) recorded during the 11 August 2010 survey. Higher radon values are displayed in yellow through orange to red hues, lower values are displayed in navy through dark blue to green tones. Higher silicate concentrations are in red to pink through orange tones, low silicate concentrations in blue tones.

Concentrations of nitrate, phosphate and silicate levels were all within accepted EPA threshold limits for water quality (Lucey et al., 1999); however, relatively higher nitrate, phosphate and silicate concentrations were recorded in the upper reaches of the estuary but also around the tip of the Hook peninsula (Figs 4.8–4.10).

4.3 Geochemical Tracing II: A Case Study of Kinvarra, Co. Galway

The results from the first in-situ 24-h sampling campaign at Dungaure Castle undertaken in July 2010 (Fig. 4.11) clearly illustrate how peaks in radon activity levels are accompanied by a substantial freshening and cooling of previously saline nearshore waters associated with low tide, as illustrated through the continuous conductivity and temperature data. At peak high tide, radon activities are at a minimum but conductivity levels are at a maximum, thus demonstrating the variance of groundwater discharging from the spring during high and low tides. However, it is also apparent from the data that there is a lag between low (high) tide and peak (minimum) radon activity levels, which suggests that as low tide commences the initial seepage measured from the

spring likely comprises recirculated seawater, seawater that entered the aquifer during flood tide, and this lag is also visible within the conductivity data. This result is consistent with work from previous studies which have shown that tidal pumping as well as wave movement results in the infiltration of seawater at high tide and the draining of seawater towards low tide (Li et al., 1999; Burnett and Dulaiova, 2003).

A repeat in-situ continuous survey was conducted at Dungaure Castle during the June 2011 campaign, with the exception that water samples for analysis were drawn repeatedly from a point closest to the spring outflow from the bedrock at the margin of the Bay and not at distance from the outflow. The graph of radon, conductivity and water depth differs from the first campaign and radon activities are high, averaging over 3,500 Bq/m³ during the survey. It is not surprising then that, overall, the highest marine radon activity levels were recorded during this survey (8,000 Bq/m³) and it is clear that tidal impacts on the analyses, such as dilution from flood waters, are reduced by sampling directly at the source (Fig. 4.12). This is to be expected naturally, because as you sample further from the

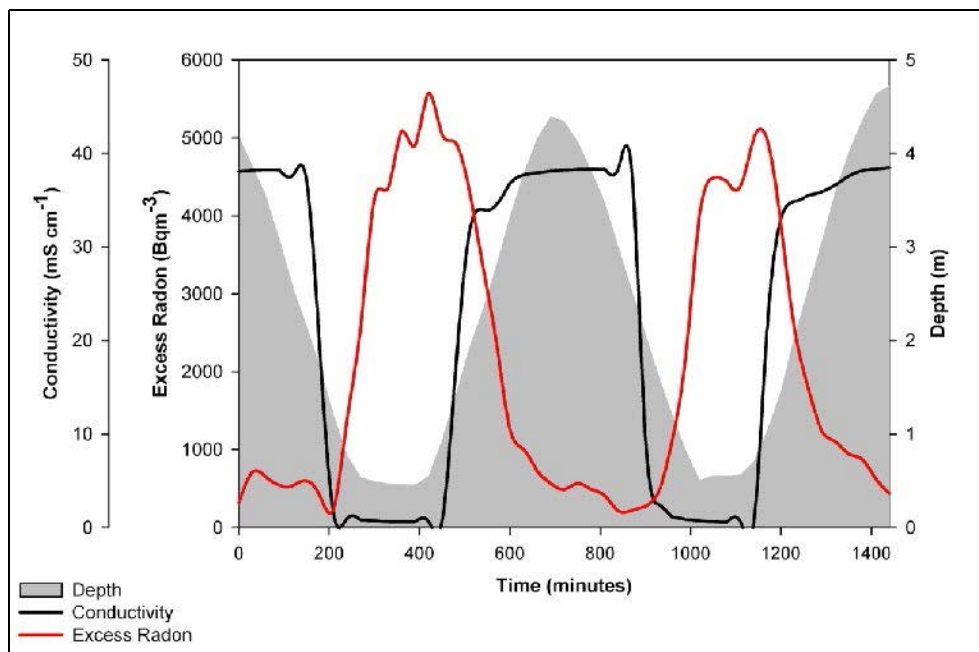

Figure 4.11. Continuous monitoring of radon, water level and conductivity at Dungaure Castle over two tidal cycles from 18:30 h 11 July (0 min) through 18:30 h 12 July (1,440 min) 2010 reveals tidal influence on groundwater discharge. Periods of high radon activity are associated with low tide and low conductivity (salinity). Periods of low radon activity are associated with high tide and high conductivity (salinity).

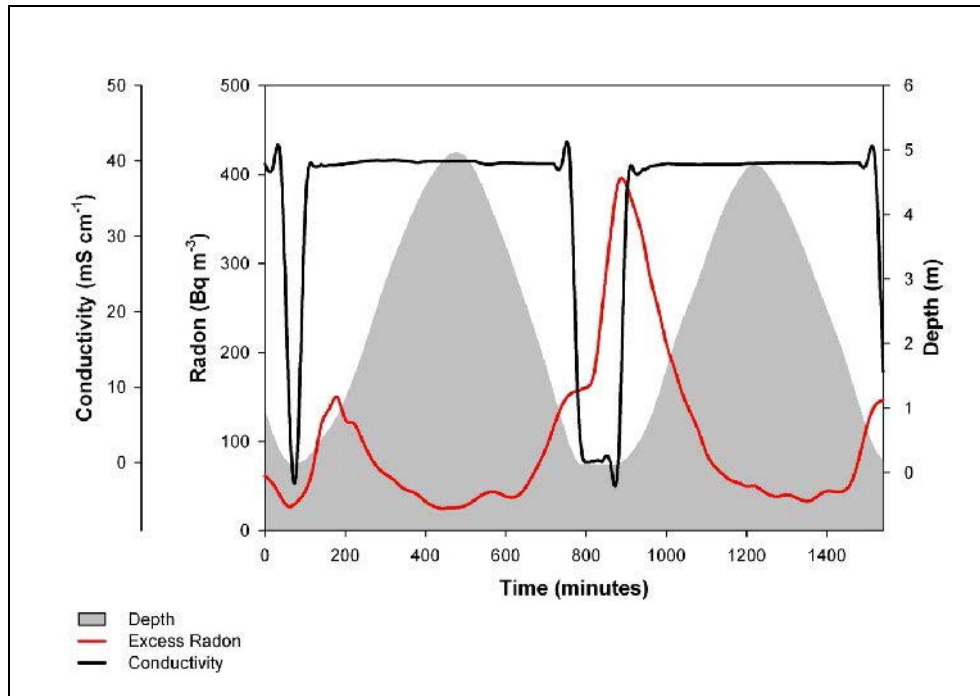

Figure 4.12. Continuous monitoring of radon, water level and conductivity at groundwater spring, Dungaure Castle, from 09:00 h 20 June (0 min) through 06:00 h 21 June 2011 (1,260 min).

source of groundwater the impact of dilution is greater resulting in lower radon activity levels due to mixing between fresh groundwater discharge and incoming flood waters.

The radon mass balance calculations for Kinvarra were derived from the Parkmore Pier in-situ radon survey data (the outlet into Galway Bay) specifically to determine groundwater discharge rates relative to the total flow of water into and out of the system during the ebb and flood tides, respectively. In the first instance, the results show that the system drains faster than it fills given that for each of the tidal cycle experiments ebb tide occurred on average over a shorter period of time in comparison with flood. Changes in water level between radon measurements were recorded for the duration of the 24-h surveys and ebb and flood tide timescales averaged 5.6 h and 6 h, respectively (Table 4.5). During the second survey at Parkmore Pier, undertaken on 22 June 2011, total flood tide measurements were, on average, shorter in duration due to the fact that survey measurements were truncated before peak high tide.

A comparison of time-integrated discharge volumes (calculated by multiplying changes in water level over time by the estimated surface area of Kinvarra Bay at each measurement interval) calculated during ebb and flood tides for each of the surveys reveals that more water leaves the system during ebb tide than re-enters the system during flood for the first and second surveys. In the third survey, the water exchanges are within the same order of magnitude. Ebb and flood specific groundwater discharge rates (calculated by averaging the sum of the time-integrated radon fluxes for each ebb and flood period and dividing by the groundwater endmember radon activity measured at the source) are summed to determine net groundwater discharge fluxes at Parkmore Pier of between 1.55 and 7.13×10^{-1} m per tidal period. It is not surprising that the values are low given that the mass balance was determined using radon calculations measured a considerable distance from the groundwater source and radon losses due to mixing were not quantified. This work clearly highlights the potential of geochemical tracing to assess the tidal variance of SGD inputs in a small coastal bay; however, further work is needed to quantify mixing rates and, more importantly, the residence time of water within the Bay

Table 4.5. Results from the radon mass balance approach to quantify the amount of submarine groundwater discharging into Kinvarra Bay following three in-situ surveys undertaken in 2010 (14 July) and 2011 (22 June, 6 September).

Date	Summary	Time interval (h)	Time-integrated discharge (m ³)	Time-integrated flux radon (Bq/m ²)	Groundwater endmember (Bq/m ³)	Groundwater discharge (m per tidal period)
14 July 2010	Ebb	5.5	-1.38 × 10 ⁷	-5.56 × 10 ³		-7.41 × 10 ⁻¹
	Flood	6.67	1.23 × 10 ⁷	1.09 × 10 ⁴		1.45 × 10 ¹
	Net flux			5.53 × 10³		7.13 × 10⁻¹
	Approx. extraneous flow over each tidal cycle (m³)		-1.46 × 10⁶			
22 June 2011	Ebb	5.833	-7.32 × 10 ⁶	-3.27 × 10 ³		-4.35 × 10 ⁻¹
	Flood	5	6.13 × 10 ⁶	5.85 × 10 ³	7,500	7.80 × 10 ⁻¹
	Net flux			2.58 × 10³		3.44 × 10⁻¹
	Approx. extraneous flow over each tidal cycle (m ³)		-1.18 × 10⁶			
6 September 2011	Ebb	5.5	-7.50 × 10 ⁶	-8.58 × 10 ²		-5.00 × 10 ⁻²
	Flood	6.5	7.67 × 10 ⁶	1.50 × 10 ³		2.05 × 10 ⁻¹
	Net flux			6.37 × 10²		1.55 × 10⁻¹
	Approx. extraneous flow over each tidal cycle (m³)		1.70 × 10⁵			

if we are to establish with any precision the environmental impacts of SGD-borne nutrients on the marine environment.

The results from the nutrient analyses at the groundwater source, Dunguaire Castle, during the first field campaign revealed a consistent temporal pattern linked to the tide. During high tide, nitrate and silicate levels are at a minimum due to dilution and recirculation of seawater whereas, during ebb tide, concentrations of both nutrients rise sharply (Fig. 4.13). The sharp rise in nutrient levels is evident when conductivity levels are at a minimum and it is very clear from the data that the rise in nutrients is associated with discharges of fresh groundwater. A similar pattern was observed at Parkmore Pier (Fig. 4.14); however, the maximum nitrate and silicate concentrations recorded are approximately three times higher at Dunguaire Castle. During the second campaign at Dunguaire, June 2011, it can be seen that, when water samples are gathered immediately from the source (Fig. 4.15), the temporal trend in nitrate and silicate levels observed exactly mirrors radon activity levels and, by inference, groundwater

discharge. This clearly shows that the magnitude and variation of nutrient loading into Kinvarra Bay from Dunguaire Castle is explicitly linked to groundwater discharges and not the tide. Over the sampling periods, nitrate levels varied at Dunguaire Castle between 0 and 1.24 mg/l and background aquifer concentrations of nitrate measured 3.16 mg/l, at a maximum, which were within EPA water quality limits (Lucey, 2006).

Kinvarra Bay is a special area of conservation (site code IE0000268), a region important for mussel and oyster farming. These preliminary investigations have highlighted the role groundwater discharge plays in transferring nutrients to Kinvarra Bay, which can potentially impact the biogeochemical budget of coastal water ecosystems. Land use in Kinvarra is predominantly agricultural and the seepage of groundwater and associated nutrients represents a potentially significant threat to the local economy (RPS, 2013). The relationship between groundwater discharge and nutrient loading needs to be quantified to provide specific nutrient loading estimates and to help fully understand coastal ecosystem responses.

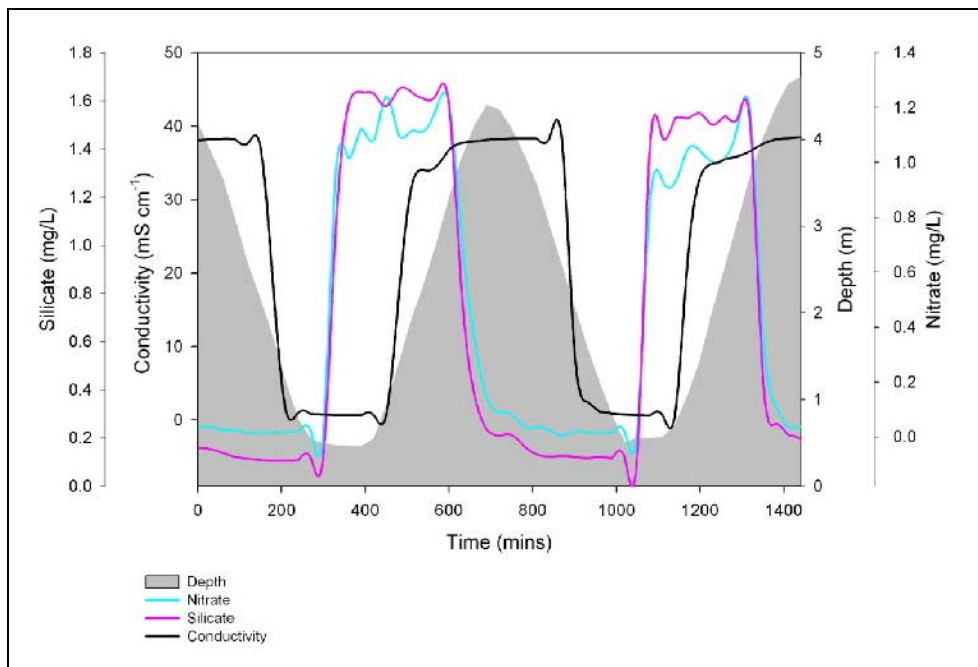

Figure 4.13. Continuous monitoring of water level, conductivity and nutrients (nitrate and silicate) at Dunguaire Castle over two tidal cycles from 11 July through 12 July 2010 reveals tidal influence on levels of silicate and nitrate.

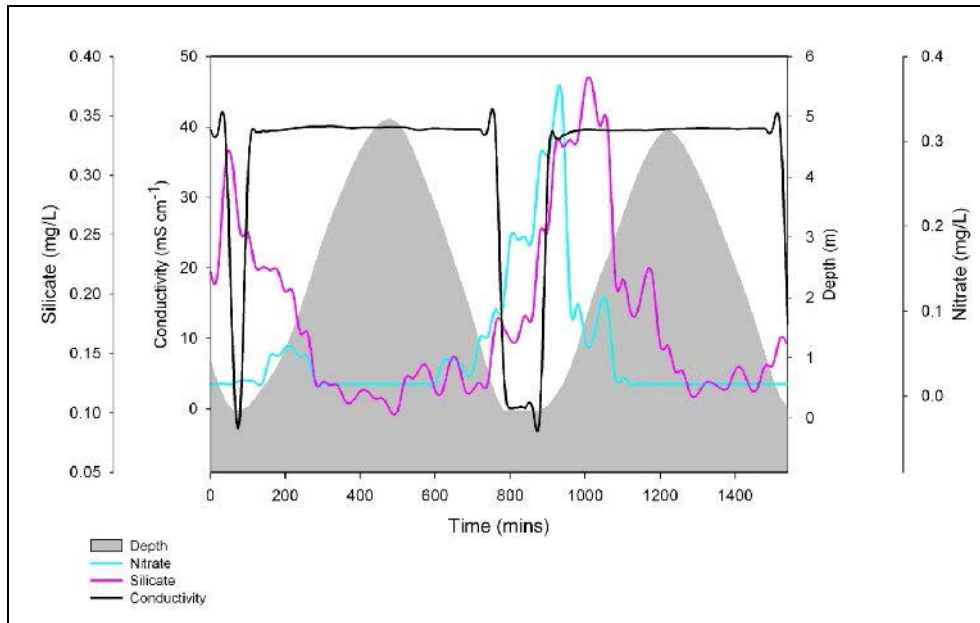

Figure 4.14. Continuous monitoring of water level, conductivity and nutrients (nitrate and silicate) at Parkmore Pier over two tidal cycles from 14 July through 15 July 2010 reveals tidal influence on levels of silicate and nitrate.

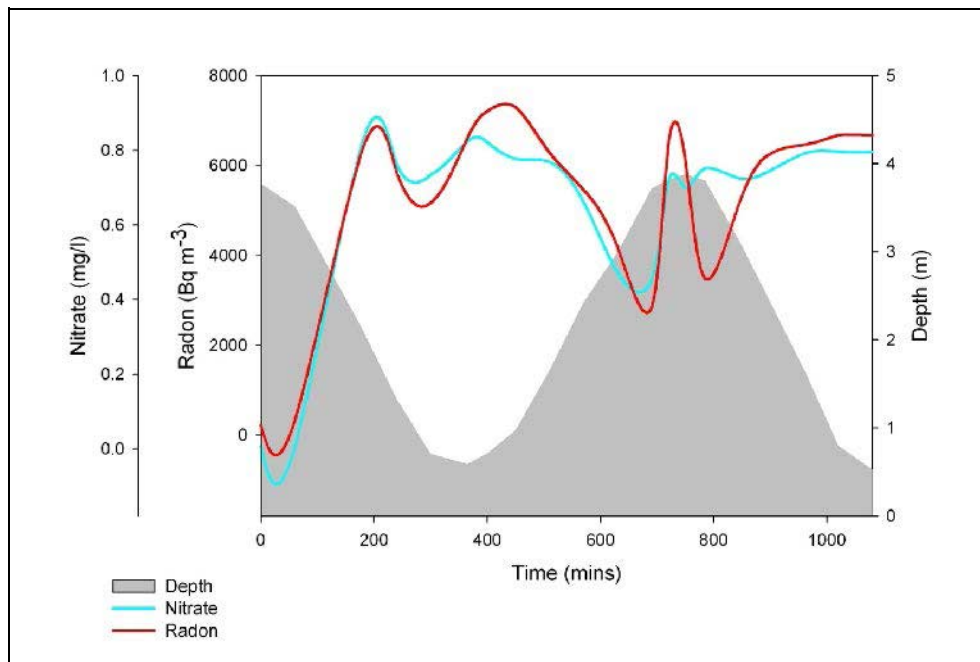

Figure 4.15. Continuous monitoring of radon and nutrients (nitrate and silicate) sampled directly from the source at Dungaure Castle over two tidal cycles from 20 June through 21 June 2011.

To quantify the nutrient load being delivered into the Bay from groundwater sources by simply multiplying the nutrient results by groundwater discharge flow as determined from a radon mass balance would be

grossly underestimating what is actually happening within the Bay as the amount of removal needs to be accounted for in order to accurately determine what nutrients remain, residing in either the bay sediment or

dissolved within the water column. Furthermore, the quality of any water body is controlled in part by the water's residence time. This is particularly pertinent for Kinvarra given that previous studies have shown a direct correlation between water residence time and the amount of denitrification that occurs in a coastal embayment (Nixon et al., 1996) and quantifying residence time is crucial to constraining land/sea nitrogen budgets as well as understanding the sensitivity of coastal systems to contaminant loads (Brooks et al., 1999). Future work should concentrate on identifying the dominant nitrogen source so that the impacts on primary production can be attributed to specific activities on land (i.e. agriculture, sewage effluent, etc.) so that local decision makers can better understand and manage land use and development.

4.3.1 Estimating water residence times using the radium quartet

Measurements of the naturally occurring radium isotopes were undertaken across Kinvarra Bay in a pilot project to determine water residence times, specifically relative ages using the activity ratio of the short-lived radium isotopes ^{224}Ra and ^{223}Ra (Table 4.6) from a series of 12 moored buoys (8–9 September 2012) ranged between 2.5 days and 10.5 days with an overall average apparent age of 7.9 days. When mapped, the spatial distribution of water ages reveals a clear pattern (Fig. 4.16). The 'oldest' water was concentrated in the central section of the Bay (Fig. 3.7, sample point 7) and the 'youngest' water was

recorded at Cars Island Quay (Fig. 3.7, sample point 9) and Dungaure Castle (Fig. 3.7, sample point 12). This is consistent with the results so far where, through a combined remote sensing and geochemical tracing approach, both Dungaure Castle and Cars Island Quay have been identified and validated as groundwater sources.

It should be noted, however, that the technique used here to determine apparent water ages is based on the fact that both isotopes are lost from the system by mixing but only ^{224}Ra is lost through radioactive decay. The mixing and decay terms along with fresh radium inputs are incorporated into the residence time equation assuming the system is in steady state. Water that is removed from the system during ebb tide and returns to the system during flood tide is considered never to have left the system. This means that there is no new input of radium into the system as a result of returning tidal flow. The apparent age is a measure of how long the tracer remains in Kinvarra Bay and an inherent difficulty when using this approach is that we do not necessarily know the areal extent in which the radium sample is integrating (Rapaglia et al., 2010). Furthermore, an important challenge to overcome when using this approach is in determining the appropriate endmember for the radium activity ratios calculation, which is based on knowledge of the radium activity ratio in the source water. In this study, sample locations are well distributed across the Bay and fibres were analysed from the surface layer

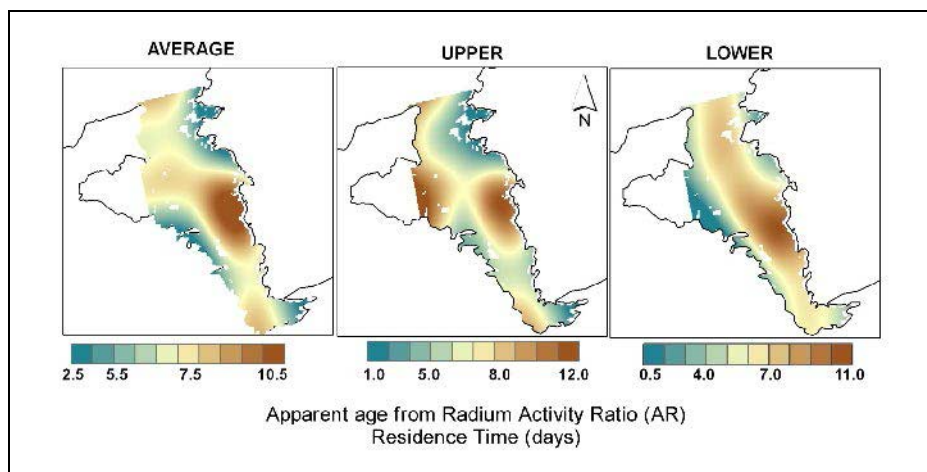

Figure 4.16. Distribution of water residence times in Kinvarra Bay calculated using radium activity ratios ($^{224}\text{Ra}/^{223}\text{Ra}$).

Table 4.6. Results from radium experiment conducted across Kinvarra Bay on 8 September 2011 to determine water residence times (relative ages) using the activity ratio of the short-lived radium isotopes ^{224}Ra and ^{223}Ra .

Sample no.	^{220}Rn cpm [^{224}Ra] (measurement no. 1)	Analysis date	^{219}Rn cpm [^{223}Ra] (measurement no. 2)	Analysis date	Supported ^{220}Rn cpm [^{228}Th] (measurement no. 3)	AR 224:223	Relative age (days)
1 Upper	46.75	18 September 2011	10.87	19 October 2011	2.91	4.03	8.2
1 Lower	37.51	17 September 2011	8.34	17 October 2011	4.20	3.99	8.2
2 Upper	77.22	22 September 2011	15.70	20 October 2011	5.26	4.58	7.2
2 Lower	60.39	20 September 2011	13.01	20 October 2011	4.13	4.32	7.6
3 Upper	102.53	23 September 2011	19.76	21 October 2011	5.99	4.88	6.7
3 Lower	37.31	17 September 2011	8.85	19 October 2011	2.90	3.88	8.4
4 Upper	27.62	14 September 2011	9.71	17 October 2011	1.19	4.81	6.8
4 Lower	10.68	11 September 2011	4.75	12 October 2011	0.64	5.05	6.5
5 Upper	39.65	17 September 2011	9.71	19 October 2011	2.04	3.87	8.5
5 Lower	22.67	14 September 2011	4.75	16 October 2011	1.15	4.53	7.3
6 Upper	35.59	17 September 2011	8.08	19 October 2011	1.99	4.53	7.3
6 Lower	16.93	12 September 2011	4.17	12 October 2011	2.03	3.57	9.1
7 Upper	38.34	18 September 2011	11.66	20 October 2011	2.58	3.07	10.3
7 Lower	14.01	12 September 2011	3.99	12 October 2011	0.80	3.31	9.7
8 Upper	29.73	16 September 2011	8.28	17 October 2011	1.89	3.36	9.6
8 Lower	15.56	13 September 2011	4.92	13 October 2011	1.09	2.94	10.6
9 Upper	3.62	10 September 2011	0.66	12 October 2011	–	5.72	5.5
10 Upper	57.72	19 September 2011	11.33	20 October 2011	2.91	4.84	6.8
10 Lower	24.80	14 September 2011	5.99	16 October 2011	1.39	3.90	8.4
11 Upper	22.68	13 September 2011	5.22	13 October 2011	1.64	4.03	8.2
11 Lower	21.78	13 September 2011	4.94	13 October 2011	0.93	4.22	7.8
12 Upper	21.42	14 September 2011	3.57	17 October 2011	1.61	5.54	5.8
12 Lower	17.87	13 September 2011	3.66	13 October 2011	1.24	4.55	7.3

and at depth to account for stratification in the water column. Source activity (endmember) ratio was determined from an independent sample taken from Dunguaire Castle immediately prior to mooring the buoys.

Visual inspection of the spatial distribution of apparent water age, as derived from the surface layers and at depth ([Fig. 4.16](#)), reveals subtle differences. At the surface, the 'youngest' water is located around Dunguaire Castle and Cars Island Quay, whereas results from the lower levels reveal a slightly different pattern in that the 'youngest' water is concentrated along the margins and the 'older' water forms a channel down the centre of the Bay. Overall the pattern suggests that the circulation in Kinvarra causes water to pool in the central section of the Bay and this has

important implications for nutrient uptake and availability. The highest nutrient concentrations during the Kinvarra Bay survey at high and low tide were located in the SGD source areas, which coincide with the pattern of 'young' water illustrated in the map of apparent water ages. This work highlights the potential application of radium isotopes as a technique for determining apparent water ages using activity ratios. However, this study has simply provided a snapshot of water mass age within Kinvarra from a sample date in September. Further work is needed to determine whether seasonal variations in the contribution of groundwater discharge to Kinvarra will cause significant changes in apparent water ages and hence nutrient availability and uptake.

5 Conclusions and Recommendations

5.1 Application of Remote Sensing in the Detection, Quantification and Evaluation of SGD

- Measurements of SST from space can be successfully used to detect locations of SGD in nearshore and offshore waters around the coastline of Ireland and into lakes.
- A comprehensive cost-effective technique for deriving SSTs, TA and STA maps (for inter-scene comparisons) developed as part of this research highlights the suitability of the approach for a regional-scale survey of potential SGD locations.
- By combining GIS-mapped TAs with ancillary on-shore spatial data sets describing bedrock geology, including aquifer fault lines, potential sites of SGD can be linked to, and associated with, specific features on land acting as possible sources (detailed within the End of Project Report).
- Concurrent measurements of geochemical tracers can be used successfully to verify that the observed thermal anomalies are the result of groundwater discharges and not some other coastal process.
- The methodology developed is not limited to the coastal zone but can be applied wherever temperature gradients exist between discharging groundwater and surface water bodies, thus presenting a comprehensive cost-effective tool for coastal managers to detect potential land-based sources of pollution to nearshore waters or lakes.
- Remote sensing has already been proposed as an investigative tool by the EPA in the context of the WFD monitoring and the results of this work have shown the importance of SGD by identifying over 35 previously unidentified links between aquifers on land and the sea. Groundwater discharge to coastal waters should be monitored on an annual basis, where image availability permits using the developed methodology to determine whether there are any observed differences in the location and extent of potential groundwater discharge sites that may warrant further/in-situ investigation.
- The technique could be applied to a national assessment of lakes. The current work was limited to one pilot site but the results clearly highlighted the success and suitability of the combined remote sensing and geochemistry approach for a regional assessment of lake water bodies.
- There is substantial scope for further development and expansion of the remote sensing technique already developed by exploring the potential of additional freely available remote sensing data sets. Several studies have demonstrated that remote sensing can be used to map water quality parameters such as temperature, turbidity (clarity), chlorophyll-*a* and total suspended solids. These parameters can be derived relatively cheaply from remote sensing imagery and potentially used to further characterise the areas identified as SGD hot spots across Irish water bodies aiming, for instance, to expose the link between SGD and nutrient enrichment.
- Surface currents and general circulation in lakes and coastal environments can be quantified using a time series of thermal imagery as for each Landsat ETM+ image there is a corresponding ASTER image acquired 40 min later. Cost-effective integrated multisensor remote sensing and GIS techniques could hence be employed systematically to provide up-to-date indicators of the current environmental status of nearshore and lake waters.
- Further development and application of remote sensing methods will provide land and coastal

managers with a cost-effective catchment-scale perspective as well as facilitating the selection of target/problematic areas for more detailed (and costly) investigations.

5.2 Geochemical Tracing Techniques for SGD Assessment, Quantification and Evaluation

- This research provides strong support for the application of and potential for geochemical tracing techniques that qualitatively and quantitatively assess groundwater discharge and associated nutrient loading in Ireland. For all three pilot sites, Hook Head, Co. Wexford, Kinvarra, Co. Galway, and Lough Mask, Co. Mayo, SGD is occurring and is a source of nutrients.
- This study demonstrates the suitability of geochemical tracers in a supporting role to the remote sensing techniques developed by facilitating a qualitative analysis of the stretches of coastline where land–sea fluxes are shown to occur.
- Radon–salinity mixing models help distinguish between the possible sources of radon and, hence, fresh water to coastal waters and eliminate estuarine outflow as the potential origin of the observed thermal anomalies and their concurrent radon activities.
- The combined remote sensing and geochemical tracing approach revealed that groundwater discharges at the coast are accompanied by a substantial cooling and freshening of nearshore waters and elevated radon activity levels.
- The radon mass balance approach can be used to quantify groundwater inputs, providing that all the sources and sinks of radon into the system can be identified. Groundwater discharge rates determined for Hook Head and Lough Mask ranged between $2.43\text{--}7.81 \times 10^4 \text{ m}^3/\text{day}$ and $2.0\text{--}3.4 \times 10^5 \text{ m}^3/\text{day}$, respectively. Groundwater discharge rates determined from in-situ surveys at Parkmore Pier ranged between 1.55 and 7.13 m per tidal cycle.
- These preliminary investigations have highlighted the role groundwater discharge plays in transferring nutrients to nearshore waters off Hook, Kinvarra Bay and Lough Mask, which can potentially impact the biogeochemical budget of marine ecosystems.
- Water residence time is an important parameter in coastal processes and is often difficult to determine. Through a pilot study, this research demonstrated the utility of the short-lived isotopes (^{224}Ra , ^{223}Ra) in deriving water residence time (apparent water ages) and, hence, SGD-borne contaminant exposure for application to a small coastal inlet in Ireland (Kinvarra Bay) and revealed that groundwater and nutrients entering the system from the source may remain within the Bay for up to 10 days, whilst further detailing specific areas within the Bay where these waters might accumulate for longer periods. These sets of results might be employed, if the technique is used to that end, to build ecological risk maps within coastal embayments and surface water bodies revealing areas of higher pollutant accumulation risk, with obvious utility for managers and stakeholders involved in licensing activities.
- Currently, national regulations define precisely how our coasts and inland waters should be monitored for nutrients, specifying which water quality parameters have to be measured and the spatial and temporal requirements for these measurements. These measurements are mostly taken as in-situ water samples. The maintenance of such monitoring programmes is expensive and the pressure on state agencies to reduce their expenses while simultaneously meeting the requirements of international regulations is fuelling the demand for more cost-effective methods. Given the demonstrated potential, further research is needed to expand both the remote sensing and geochemical tracing techniques beyond the confines of this fellowship programme, with the specific aim of applying the combined suite of analysis tools in a case study of a problematic catchment, incorporating preferentially a suite of water-body typologies.

The relevant authorities, such as inland water-body/coastal managers and policy makers, could then be informed specifically on the pathways (sources), magnitude and flux rates of groundwater and associated nutrient load discharging into nearshore waters and lakes,

thus contributing directly to the environmental objectives set by the WFD and further expanding those in the spirit of the land–ocean continuum established within the Marine Strategy Framework Directive (MSFD 2008/56/EC).

References

- Abrams, M., 2000. The advanced spaceborne thermal emission and reflection radiometer (aster): data products for the high spatial resolution imager on NASAs terra platform. *International Journal of Remote Sensing* **21**: 847–859.
- Anderson, M.P., 2004. Heat as a groundwater tracer. *Ground Water* **43(6)**: 951–968.
- Anderson, D.M., 2009. Approaches to monitoring, control and management of harmful algal blooms (HABs). *Ocean and Coastal Management* **52**: 342–347.
- Barnes, W.L., Pagano, T.S. and Salomonson, V.V., 1998. Prelaunch characteristics of the Moderate Resolution Imaging Spectroradiometer (MODIS) on EOS-AMI. *IEEE Transactions on Geoscience and Remote Sensing* **36**: 1088–1100.
- Barsi, J.A., Schott, J.R., Palluconi, F.D., Helder, D.L., Hook, S.J. and Markham, B.L., 2003. Landsat TM and ETM+ thermal band calibration. *Canadian Journal of Remote Sensing* **29**: 141–153.
- Beck, A.J., Rapaglia, J.P., Cochran, J.K. and Bokuniewicz, H.J., 2007. Radium mass-balance in Jamaica Bay, NY: Evidence for a substantial flux of submarine groundwater. *Marine Chemistry* **106**: 419–441.
- Boehm, A.B., Shellanbarger, G.G. and Paytan, A., 2004. Groundwater discharge: potential association with fecal indicator bacteria in the surf zone. *Environment Science and Technology* **38**: 3558–3566.
- Brooks, D.A., Baca, M.W. and Lo, Y.-T., 1999. Tidal circulation and residence time in a macrotidal estuary: Cobscook Bay, Maine. *Estuarine, Coastal Shelf Science* **49**: 647–665.
- Burnett, W.C. and Dulaiova, H., 2003. Estimating the dynamics of groundwater input into the coastal zone via continuous radon-222 measurements. *Journal of Environmental Radioactivity* **69**: 21–35.
- Burnett, W.C. and Dulaiova, H., 2006. Radon as a tracer of submarine groundwater discharge into a boat basin in Donnalucata, Sicily. *Continental Shelf Research* **26**: 862–873.
- Burnett, W.C., Taniguchi, M. and Oberdorfer, J.A., 2001. Assessment of submarine groundwater discharge into the coastal zone. *Journal of Sea Research* **46**: 109–116.
- Burnett, W.C., Aggarwal, P.K., Aureli, A., Bokuniewicz, H., Cable, J.E., Charette, M.A., Kontar, E., Krupa, S., Kulkarni, K.M., Loveless, A., Moore, W.S., Oberdorfer, J.A., Oliveira, J., Ozyurt, N., Povinec, P., Privitera, A.M.G., Rajar, R., Ramessur, R.T., Scholten, J., Stieglitz, T., Taniguchi, M. and Turner, J.V., 2006. Quantifying submarine groundwater discharge in the coastal zone via multiple methods. *Science of The Total Environment* **367**: 498–543.
- Burnett, W.C., Peterson, R., Moore, W.S. and De Oliveira, J., 2008. Radon and radium isotopes as tracers of submarine groundwater discharge – results from the Ubatuba, Brazil SGD assessment intercomparison. *Estuarine, Coastal and Shelf Science* **76**: 501–511.
- Cable, J.E., Burnett, W.C. and Chanton, J.P., 1997. Magnitude and variations of groundwater seepage along a Florida marine shoreline. *Biogeochemistry* **38**: 189–205.
- Charette, M.A. and Allen, M.C., 2006. Precision groundwater sampling in coastal aquifers using a direct push shielded screen well-point system. *Groundwater Monitoring and Remediation* **26**: 87–93.
- Charette, M.A., Buesseler, K.O. and Andrews, J.E., 2001. Utility of radium isotopes for evaluating the input and transport of groundwater-derived nitrogen to a Cape Code estuary. *Limnology and Oceanography* **46**: 465–470.
- Corbett, D.R., Chanton, J.P., Burnett, W.C., Dillon, K., Rutkowski, C. and Fourqurean, J.W., 1999. Patterns of groundwater discharge into Florida Bay. *Limnology and Oceanography* **44**: 1045–1055.
- Corbett, D.R., Dillon, K., Burnett, B. and Chanton, J., 2000. Estimating the groundwater contribution into Florida Bay via natural tracers ^{222}Rn and CH_4 . *Limnology and Oceanography* **45(7)**: 1546–1557.
- Corlett, G.K., Barton, I.J., Donlon, C.J., Edwards, M.C., Good, S.A., Horrocks, L.A., Llewellyn-Jones, D.T., Merchant, C.J., Minnett, P.J., Nightingale, T.J., Noyes, E.J., O'Carroll, A.G., Remedios, J.J., Robinson, I.S., Saunders, R.W. and Watts, J.G., 2006. The accuracy of SST retrievals from AATSR: An initial assessment through geophysical validation against in-situ radiometers, buoys and other SST data sets. *Advances in Space Research* **37(4)**: 764–769.
- Dale, R.K. and Miller, D.C., 2007. Spatial and temporal patterns of salinity and temperature at an intertidal groundwater seep. *Estuarine, Coastal and Shelf Science* **72**: 283–298.
- Dalton, C., Jennings, E., Taylor, D., O'Dwyer, B., Murnaghan, S., Bosch, K., De Eyto, E. and Sparber, K., 2005. *Past, Current and Future Interactions Between Pressures, Chemical Status and Biological*

- Quality Elements for Lakes in Contrasting Catchments in Ireland (ILLUMINATE)*. Environmental Protection Agency, Johnstown Castle Estate, Wexford, Ireland.
- DoELG/EPA/GSI, 1999. *Groundwater Protection Schemes*. Department of the Environment and Local Government, Environmental Protection Agency and Geological Survey of Ireland, Dublin, Ireland.
- Drew, D., 2001. *Classic Landforms of the Burren Karst*. Geographical Association, Sheffield, UK.
- Drew, D.P. and Daly, D., 1993. *Groundwater and Karstification in Mid-Galway, South Mayo and North Clare*. A Joint Report: Department of Geography, Trinity College Dublin and Groundwater Section, Geological Survey of Ireland. Geological Survey of Ireland Report Series 93/3 (Groundwater), 86 pp.
- Dulaiova, H., Peterson, R., Burnett, W.C. and Lane-Smith, D., 2005. A multidetector continuous monitor for assessment of ^{222}Rn in the coastal ocean. *Journal of Radioanalytical and Nuclear Chemistry* **263**: 361–365.
- Dulaiova, H., Gonneea, M.E., Henderson, P.B. and Charette, M.A., 2008. Geochemical and physical sources of radon variation in a subterranean estuary – Implications for groundwater radon activities in submarine groundwater discharge studies. *Marine Chemistry* **110**: 120–127.
- Esaias, W.E., Abbott, M., Barone, L., Brown, O., Campbell, J., Carder, K., Clark, D., Evans, R., Hodge, F., Gordon, H., Balch, W., Letelier, R. and Minnett, P., 1998. An overview of MODIS capabilities for ocean science observations. *IEEE Transactions on Geoscience and Remote Sensing* **36**: 1250–1265.
- Felipe, H., Niencheski, L., Windom, H.L., Moore, W.S. and Jahnke, R.A., 2007. Submarine groundwater discharge of nutrients to the ocean along a coastal lagoon barrier, Southern Brazil. *Marine Chemistry* **106**: 546–561.
- Fisher, J.I. and Mustard, J.F., 2004. High spatial resolution sea surface climatology from Landsat thermal infrared data. *Remote Sensing of Environment* **90**: 293–307.
- Fox, M.F., Kester, D.R. and Yoder, J.A., 2005. Spatial and temporal distributions of surface temperature and chlorophyll in the Gulf of Maine during 1998 using SeaWiFS and AVHRR imagery. *Marine Chemistry* **97**: 104–123.
- Gibbons, D.E. and Wukelic, G.E., 1989. Application of Landsat thematic mapper data for coastal thermal plume analysis at Diablo Canyon. *Photogrammetric Engineering and Remote Sensing* **55**: 903–909.
- Gillespie, A.R., Rokugawa, S., Matsunaga, T., Cothorn, J.S., Hook, S. and Kahle, A.B., 1998. A temperature emissivity separation algorithm for ASTER images. *IEEE Transactions on Geoscience and Remote Sensing* **36**: 1113–1126.
- Grasshoff, K., Kremling, K. and Ehrhardt, M., 1999. *Methods of Seawater Analysis*. (3rd Edn) Weinheim, Chichester, UK.
- Hancock, G.J. and Murray, A.S., 1996. Source and distribution of dissolved radium in the Bega River estuary, Southeastern Australia. *Earth and Planetary Science Letters* **138**: 145–155.
- Handcock, R.N., Gillespie, A.R., Cherkauer, K.A., Kay, J.E., Burges, S.J. and Kampf, S.K., 2006. Accuracy and uncertainty of thermal-infrared remote sensing of stream temperatures at multiple spatial scales. *Remote Sensing of Environment* **100**: 427–440.
- Houghman, A.L. and Moran, S.B., 2007. Water mass ages of coastal ponds estimated using ^{223}Ra and ^{224}Ra as tracers. *Marine Chemistry* **105**: 194–207.
- Hu, C., Muller-Karger, F.E. and Swarzenski, P.W., 2006. Hurricanes, submarine ground-water discharge and Florida's red tides. *Geophysical Research Letters* **33**: L11601.
- Hussain, N., Church, T.M. and Kim, G., 1999. Use of ^{222}Rn and ^{226}Ra to trace groundwater discharge into Chesapeake Bay. *Marine Chemistry* **65**: 127–134.
- Hwang, D.-W., Kim, G., Lee, Y.-W. and Yang, H.-S., 2005. Estimating submarine inputs of groundwater and nutrients to a coastal bay using radium isotopes. *Marine Chemistry* **96**: 61–71.
- Johannes, R., 1980. The ecological significance of the submarine discharge of groundwater. *Marine Ecological Progress Series* **3**: 365–373.
- Kilpatrick, K.A., Podesta, G.P. and Evans, R., 2001. Overview of the NOAA/NASA advanced very high resolution radiometer Pathfinder algorithm for sea surface temperature and associated matchup database. *Journal of Geophysical Research – Oceans* **106**: 9179–9197.
- Kim, G., Ryu, J.-W. and Hwang, D.-W., 2008. Radium tracing of submarine groundwater discharge (SGD) and associated nutrient fluxes in a highly-permeable bed coastal zone, Korea. *Marine Chemistry* **109**: 307–317.
- Lamontagne, S., Le Gal La Salle, C., Hancock, G.J., Webster, I.T., Simmons, C.T., Love, A.J., James-Smith, J., Smith, A.J., Kämpf, J. and Fallowfield, H.J., 2008. Radium and radon radioisotopes in regional groundwater, intertidal groundwater, and seawater in the Adelaide Coastal Waters Study area: Implications for the evaluation of submarine groundwater discharge. *Marine Chemistry* **109**: 318–336.
- Landsat Project Science Office, 2003. *Landsat 7 Science Data User's Handbook*. Goddard Space Flight Centre, NASA Washington, DC, USA.
- Lee, Y.-W. and Kim, G., 2007. Linking groundwater-borne

- nutrients and dinoflagellate red-tide outbreaks in the southern sea of Korea using a Ra tracer. *Estuarine, Coastal and Shelf Science* **71**: 309–317.
- Lee, Y.-W., Hwang, D.-W., Kim, G., Lee, W.-C. and Oh, H.-T., 2009. Nutrient inputs from submarine groundwater discharge (SGD) in Masan Bay, an embayment surrounded by heavily industrialized cities, Korea. *Science of The Total Environment* **407**: 3181–3188.
- Leote, C., Ibanhez Severino, J. and Rocha, C., 2008. Submarine groundwater discharge as a nitrogen source to the Ria Formosa studied with seepage metres. *Biogeochemistry* **88**: 185–194.
- Li, L., Barry, D.A., Stagnitti, F. and Parlange, J.-Y., 1999. Submarine groundwater discharge and associated chemical input to a coastal sea. *Water Resources Research* **35**: 3253–3259.
- Liss, P.S. and Merlivat, L., 1986. Air sea gas exchange rates: introduction and synthesis. In: Liss, P. (Ed.) *Air–Sea Exchange of Gas and Particles*. Springer, Netherlands.
- Lucey, J., 2006. *Water Quality in Ireland 2005: Key Indicators of the Aquatic Environment*. Environmental Protection Agency, Johnstown Castle Estate, Wexford, Ireland.
- Lucey, J., Bowman, J.J., Clabby, K.J., Cunningham, P., Lehane, M., MacCártaigh, McGarrigle, M. and Toner, P.F., 1999. *Water Quality in Ireland*. Environmental Protection Agency, Johnstown Castle Estate, Wexford, Ireland.
- Menzel, W.P. and Purdom, J., 1994. Introducing GOES-I, 1994: the first of a new generation of geostationary operational environmental satellites. *Bulletin of American Meteorological Society* **75**: 757–781.
- Michael, H., Charette, M. and Harvey, C.F., 2011. Patterns and variability of groundwater flow and radium activity at the coast: A case study from Waquoit Bay, Massachusetts. *Marine Chemistry* **127**: 100–114.
- Moore, W.S., 1999. The subterranean-estuary: a reaction zone of groundwater and sea water. *Marine Chemistry* **65**: 111–125.
- Moore, W.S., 2000. Determining coastal mixing rates using radium isotopes. *Continental Shelf Research* **20**: 1995–1997.
- Moore, W.S. and Arnold, R., 1996. Measurement of ^{223}Ra and ^{224}Ra in coastal waters using a delayed coincidence counter. *Journal of Geophysical Research* **101**: 1321–1329.
- Nixon, S.W., Ammerman, J.W., Atkinson, L.P., Berounsky, V.M., Billen, G., Boicourt, W.C., Boynton, W.R., Church, T.M., Ditoro, D.M., Elmgren, R., Garber, J.H., Giblin, A.E., Jahnke, R.A. and Owens, N.J.P., 1996. The fate of nitrogen and phosphorous at the land–sea margin of the North Atlantic Ocean. *Biogeochemistry* **35**: 141–180.
- Oliveira, J., Costa, P. and Braga, E.S., 2006. Seasonal variations of Rn-222 and SGD fluxes to Ubatuba embayments, Sao Paulo. *Journal of Radioanalytical Nuclear Chemistry* **269(3)**: 689–695.
- Parkinson, C.L., 2003. Aqua: an earth-observing satellite mission to examine water and other climate variables. *IEEE Transactions on Geoscience and Remote Sensing* **41**: 173–183.
- Povinec, P.P., Bokuniewicz, H., Burnett, W.C., Cable, J., Charette, M., Comanducci, J.F., Kontar, E.A., Moore, W.S., Oberdorfer, J.A., De Oliveira, J., Peterson, R., Stieglitz, T. and Taniguchi, M., 2008. Isotope tracing of submarine groundwater discharge offshore Ubatuba, Brazil: results of the IAEA-UNESCO SGD project. *Journal of Environmental Radioactivity* **99**: 1596–1610.
- Rama, A. and Moore, W.S., 1996. Using the radium quartet for evaluating groundwater input and water exchange in salt marshes. *Geochimica et Cosmochimica Acta* **60**: 4645–4652.
- Rapaglia, J.P., Ferrarin, C., Zaggia, L., Moore, W.S., Umgiesser, G., Garcia-Solsona, E., Garcia-Solsona, J. and Masque, P., 2010. Investigation of residence time and groundwater flux in Venice Lagoon: comparing radium isotope and hydrodynamical models. *Journal of Environmental Radioactivity* **101**: 571–581.
- RPS, 2013. *Draft Gort Local Area Plan (2013–2019) Screening for Appropriate Assessment and Natura Impact Report*. RPS, Ireland. Retrieved from <http://www.galway.ie/en/Services/Planning/DevelopmentPlans/LocalAreaPlans/DraftPlans/> [last accessed March 2013].
- Schmidt, A. and Schubert, M., 2007. Using radon-222 for tracing groundwater discharge into an open-pit lignite mining lake – a case-study. *Isotopes in Environmental and Health Studies* **43**: 387–400.
- Schmidt, A., Reyss, J.-L., Landré, F. and Boust, D., 1998. Distribution and flux of ^{226}Ra and ^{228}Ra in the Irish Sea and in the English Channel, in relation with hydrological conditions and sediment interactions. *Radiation Protection Dosimetry* **75**: 65–67.
- Schmidt, A., Gibson, J.J., Santos, I.R., Schubert, M., Tattre, K. and Weiss, H., 2010. The contribution of groundwater discharge to the overall water budget of two typical Boreal lakes in Alberta/Canada estimated from a radon mass balance. *Hydrology and Earth System Sciences* **14**: 79–89.
- Schwartz, M.C., 2003. Significant groundwater input to a coastal plain estuary: assessment from excess radon. *Estuarine, Coastal and Shelf Science* **56**: 31–42.
- Shaban, A., Khawlie, M., Abdallah, C. and Faour, G.,

2005. Geologic controls of submarine groundwater discharge: application of remote sensing to north Lebanon. *Environmental Geology* **47**: 512–522.
- Slomp, C.P. and Van Cappellen, P., 2004. Nutrient inputs to the coastal ocean through submarine groundwater discharge: controls and potential impact. *Journal of Hydrology* **295**: 64–86.
- Stieglitz, T., 2005. Submarine groundwater discharge into the near-shore zone of the Great Barrier Reef, Australia. *Marine Pollution Bulletin* **51**: 51–59.
- Stieglitz, T.C., Cook, P.G. and Burnett, W.C., 2010. Inferring coastal processes from regional-scale mapping of ²²²Rn and salinity: examples from the Great Barrier Reef, Australia. *Journal for Environmental Radioactivity* **101**: 544–552.
- Swarzenski, P.W., Reich, C., Kroeger, K.D. and Baskaran, M., 2007. Ra and Rn isotopes as natural tracers of submarine groundwater discharge in Tampa Bay florida. *Marine Chemistry* **104**: 69–84.
- Tcherepanov, E.N., Zlotnik, V.A. and Henebry, G.M., 2005. Using Landsat thermal imagery and GIS for identification of groundwater discharge into shallow groundwater-dominated lakes. *International Journal of Remote Sensing* **26**: 3649–3661.
- Thomas, A., Byrne, D. and Weatherbee, R., 2002. Coastal sea surface temperature variability from Landsat infrared data. *Remote Sensing of Environment* **81**: 262–272.
- Valiela, I., Costa, J., Foreman, K., Teal, J.M., Howes, B. and Aubrey, D., 1990. Transport of groundwater-borne nutrients from watersheds and their effects on coastal waters. *Biogeochemistry* **10**: 177–197.
- Varma, S., Turner, J. and Underschlutz, J., 2010. Estimation of submarine groundwater discharge into Geographe Bay, Bunbury, Western Australia. *Journal of Geochemical Exploration* **106**: 197–210.
- Wang, L.T., Mckenna, T.E. and Deliberty, T.L., 2008. *Report of Investigations No. 74: Locating groundwater discharge areas in Rehoboth and Indian River Bays and Indian River Delaware using Landsat 7 imagery*. Newark, State of Delaware, Delaware Geological Survey, USA.
- Wilson, J. and Rocha, C., 2012. Regional scale assessment of submarine groundwater discharge in Ireland combining medium resolution thermal imagery and geochemical tracing techniques. *Remote Sensing of Environment* **119**: 21–34.
- Wloczyk, C., Richter, R., Borg, E. and Nueberts, W., 2006. Sea and lake surface temperature retrieval from Landsat thermal data in Northern Germany. *International Journal of Remote Sensing* **27(12)**: 2489–2502.

Acronyms and Annotations

AATSR	Advanced Along-Track Scanning Radiometer
ASTER	Advanced Spaceborne Thermal Emission and Reflection Radiometer
AVHRR	Advanced Very High Resolution Radiometer
cSAC	Candidate Special Area of Conservation
CTD	Conductivity, temperature, depth
DN	Digital Number
DoELG	Department of Environment and Local Government
EPA	Environmental Protection Agency
ESA	European Space Agency
ETM+	Enhanced Thematic Mapper Plus
EU	European Union
FIA	Flow injection analyser
GIS	Geographical Information System
GLCF	Global Land Cover Facility
GPS	Global Positioning System
GSI	Geological Survey of Ireland
Landsat ETM+	Landsat Enhanced Thematic Mapper Plus
LST	Lake Surface Temperature
MERIS	Medium Resolution Imaging Spectrometer
MI	Marine Institute
Mn	Manganese
MODIS	Moderate Resolution Imaging Spectrometer
NASA	National Aeronautics and Space Administration
NETD	Noise Equivalent Temperature Difference
NH₃	Ammonia
NHA	Natural Heritage Area
NO₂	Nitrite
NO₃	Nitrate
NOAA	National Oceanographic and Atmospheric Administration
Po	Polonium
Ra	Radium
RaDeCC	Delayed Radium Coincidence Counter

Rn	Radon
SCA	Special Area of Conservation
SGD	Submarine Groundwater Discharge
Si	Silicon
SLC	Scan Line Corrector
SPA	Special Protection Area
SST	Sea Surface Temperature
STA	Standardised Temperature Anomaly
TA	Temperature Anomaly
TIMS	Thermal Infrared Multispectral Scanner
TIR	Thermal Infrared
TM	Thematic Mapper
TOA	Top of Atmosphere
USGS	United States Geological Survey
WFD	Water Framework Directive
WRS	World Reference System

An Ghníomhaireacht um Chaomhnú Comhshaoil

Is í an Ghníomhaireacht um Chaomhnú Comhshaoil (EPA) comhlachta reachtúil a chosnaíonn an comhshaol do mhuintir na tíre go léir. Rialaímid agus déanaimid maoirsiú ar ghníomhaíochtaí a d'fhéadfadh truailliú a chruthú murach sin. Cinntimid go bhfuil eolas cruinn ann ar threochtaí comhshaoil ionas go nglactar aon chéim is gá. Is iad na príomhnithe a bhfuilimid gníomhach leo ná comhshaol na hÉireann a chosaint agus cinntiú go bhfuil forbairt inbhuanaithe.

Is comhlacht poiblí neamhspleách í an Ghníomhaireacht um Chaomhnú Comhshaoil (EPA) a bunaíodh i mí Iúil 1993 faoin Acht fán nGníomhaireacht um Chaomhnú Comhshaoil 1992. Ó thaobh an Rialtais, is í an Roinn Comhshaoil, Pobal agus Rialtais Áitiúil.

ÁR bhFREAGRACHTAÍ

CEADÚNÚ

Bíonn ceadúnais á n-eisiúint againn i gcomhair na nithe seo a leanas chun a chinntiú nach mbíonn astuithe uathu ag cur sláinte an phobail ná an comhshaol i mbaol:

- áiseanna dramhaíola (m.sh., líonadh talún, loisceoirí, stáisiúin aistrithe dramhaíola);
- gníomhaíochtaí tionsclaíocha ar scála mór (m.sh., déantúsaíocht cógaisíochta, déantúsaíocht stroighne, stáisiúin chumhachta);
- diantalmhaíocht;
- úsáid faoi shrian agus scaoileadh smachtaithe Orgánach Géinathraithe (GMO);
- mór-áiseanna stórais peitrealí;
- scardadh dramhuisce;
- dumpáil mara.

FEIDHMIÚ COMHSHAOIL NÁISIÚNTA

- Stiúradh os cionn 2,000 iniúchadh agus cigireacht de áiseanna a fuair ceadúnas ón nGníomhaireacht gach bliain
- Maoirsiú freagrachtaí cosanta comhshaoil údarás áitiúla thar sé earnáil - aer, fuaim, dramhaíl, dramhuisce agus caighdeán uisce
- Obair le húdaráis áitiúla agus leis na Gardaí chun stop a chur le gníomhaíocht mhídhleathach dramhaíola trí chomhordú a dhéanamh ar líonra forfheidhmithe náisiúnta, díriú isteach ar chiontóirí, stiúradh fiosrúcháin agus maoirsiú leigheas na bhfadhbanna.
- An dlí a chur orthu siúd a bhriseann dlí comhshaoil agus a dhéanann dochar don chomhshaol mar thoradh ar a ngníomhaíochtaí.

MONATÓIREACHT, ANAILÍS AGUS TUAIRSCIÚ AR AN GCOMHSHAOIL

- Monatóireacht ar chaighdeán aer agus caighdeáin aibhneacha, locha, uiscí taoide agus uiscí talaimh; leibhéal agus sruth aibhneacha a thomhas.
- Tuairisciú neamhspleách chun cabhrú le rialtais náisiúnta agus áitiúla cinntí a dhéanamh.

RIALÚ ASTUITHE GÁIS CEAPTHA TEASA NA HÉIREANN

- Cainníochtú astuithe gáis ceaptha teasa na hÉireann i gcomhthéacs ár dtiomantas Kyoto.
- Cur i bhfeidhm na Treorach um Thrádáil Astuithe, a bhfuil baint aige le hos cionn 100 cuideachta atá ina mór-ghineadóirí dé-ocsaíd charbóin in Éirinn.

TAIGHDE AGUS FORBAIRT COMHSHAOIL

- Taighde ar shaincheisteanna comhshaoil a chomhordú (cosúil le caighdeán aer agus uisce, athrú aeráide, bithéagsúlacht, teicneolaíochtaí comhshaoil).

MEASÚNÚ STRAITÉISEACH COMHSHAOIL

- Ag déanamh measúnú ar thionchar phleananna agus chláracha ar chomhshaol na hÉireann (cosúil le pleananna bainistíochta dramhaíola agus forbartha).

PLEANÁIL, OIDEACHAS AGUS TREOIR CHOMHSHAOIL

- Treoir a thabhairt don phobal agus do thionscal ar cheisteanna comhshaoil éagsúla (m.sh., iarratais ar cheadúnais, seachaint dramhaíola agus rialacháin chomhshaoil).
- Eolas níos fearr ar an gcomhshaol a scaipeadh (trí cláracha teilifíse comhshaoil agus pacáistí acmhainne do bhunscoileanna agus do mheánscoileanna).

BAINISTÍOCHT DRAMHAÍOLA FHORGHNÍOMHACH

- Cur chun cinn seachaint agus laghdú dramhaíola trí chomhordú An Chláir Náisiúnta um Chosc Dramhaíola, lena n-áirítear cur i bhfeidhm na dTionscnamh Freagrachta Táirgeoirí.
- Cur i bhfeidhm Rialachán ar nós na treoracha maidir le Trealamh Leictreach agus Leictreonach Caite agus le Srianadh Substaintí Guaiseacha agus substaintí a dhéanann ídiú ar an gcrios ózóin.
- Plean Náisiúnta Bainistíochta um Dramhaíl Ghuaiseach a fhorbairt chun dramhaíl ghuaiseach a sheachaint agus a bhainistiú.

STRUCHTÚR NA GNÍOMHAIREACHTA

Bunaíodh an Ghníomhaireacht i 1993 chun comhshaol na hÉireann a chosaint. Tá an eagraíocht á bhainistiú ag Bord lánaimseartha, ar a bhfuil Príomhstíúrthóir agus ceithre Stíúrthóir.

Tá obair na Ghníomhaireachta ar siúl trí ceithre Oifig:

- An Oifig Aeráide, Ceadúnaithe agus Úsáide Acmhainní
- An Oifig um Fhorfheidhmiúchán Comhshaoil
- An Oifig um Measúnacht Comhshaoil
- An Oifig Cumarsáide agus Seirbhísí Corparáide

Tá Coiste Comhairleach ag an nGníomhaireacht le cabhrú léi. Tá dáréag ball air agus tagann siad le chéile cúpla uair in aghaidh na bliana le plé a dhéanamh ar cheisteanna ar ábhar inní iad agus le comhairle a thabhairt don Bhord.

Science, Technology, Research and Innovation for the Environment (STRIVE) 2007-2013

The Science, Technology, Research and Innovation for the Environment (STRIVE) programme covers the period 2007 to 2013.

The programme comprises three key measures: Sustainable Development, Cleaner Production and Environmental Technologies, and A Healthy Environment; together with two supporting measures: EPA Environmental Research Centre (ERC) and Capacity & Capability Building. The seven principal thematic areas for the programme are Climate Change; Waste, Resource Management and Chemicals; Water Quality and the Aquatic Environment; Air Quality, Atmospheric Deposition and Noise; Impacts on Biodiversity; Soils and Land-use; and Socio-economic Considerations. In addition, other emerging issues will be addressed as the need arises.

The funding for the programme (approximately €100 million) comes from the Environmental Research Sub-Programme of the National Development Plan (NDP), the Inter-Departmental Committee for the Strategy for Science, Technology and Innovation (IDC-SSTI); and EPA core funding and co-funding by economic sectors.

The EPA has a statutory role to co-ordinate environmental research in Ireland and is organising and administering the STRIVE programme on behalf of the Department of the Environment, Heritage and Local Government.



ENVIRONMENTAL PROTECTION AGENCY
PO Box 3000, Johnstown Castle Estate, Co. Wexford, Ireland
t 053 916 0600 f 053 916 0699
LoCall 1890 33 55 99
e info@epa.ie w <http://www.epa.ie>



Comhshaoil, Pobal agus Rialtas Áitiúil
Environment, Community and Local Government